



AT SERIES ARCHITECTURAL WALL MOUNT DIMMER OWNER'S MANUAL

Version 0.3
11/23/2022

AT SERIES ARCHITECTURAL DIMMER

Version 0.3

OWNER'S MANUAL

11/23/2022

DESCRIPTION OF UNIT

The AT series dimmer is specifically optimized for architectural applications. It can be supplied with up to four 2400 Watt lighting circuits (channels) and is provided with a fast acting 20 Amp magnetic circuit breaker for each channel. The AT series dimmer can be operated from a DMX controller or remotely located momentary contact closures to activate programmable presets. A table at the end of this manual gives a description of the different AT models.

FIGURE 1.

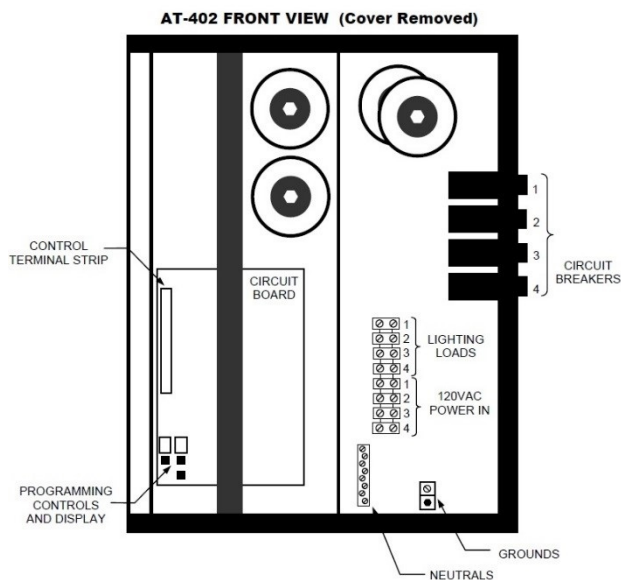

POWER REQUIREMENTS

The AT Series dimmer requires a 120 VAC hot power feed line for each lighting circuit (channel), a common neutral, and an earth ground. Each of these feeds must be powered by a circuit providing a minimum of 20 Amps and supplies only one of the AT Series dimmer lighting circuits. The power feed for channel number one also powers the unit's internal electronic circuitry. The internal circuitry is protected by a replaceable 1/2 Amp, 250 Volt, fast acting fuse. The AT dimmer may be operated from either single phase or three phase power and may be switched between these power types by the user. For 230 VAC option, a special option must be requested when ordering the AT dimmer.

INSTALLATION

LOCATION AND MOUNTING

www.lightronics.com

The unit is for INDOOR USE ONLY. It is to be wall mounted using the mounting holes provided in the chassis. Orient the unit such that the circuit board is in the lower left corner of the chassis. The unit may (but is not required to be) spaced out from the wall approximately 1 inch. This may be desirable if the unit must be used in a location with a high ambient temperature. Standard sized knockout holes are provided in the top, bottom and right side of the chassis for wiring. Be sure that the vent holes in the chassis and cover are not obstructed since they are needed for proper cooling.

INPUT POWER CONNECTIONS

WARNING!
 RISK OF ELECTRICAL SHOCK
 Make sure that power is removed from all feed circuits before proceeding with wiring.

Connect POWER INPUT leads to the lower terminal strip positions as indicated on the terminal strip labels. A hot feed line is needed for each channel. Associated NEUTRALS are to be connected to the NEUTRAL bar provided. An EARTH GROUND is required with the ground lug provided. The terminal strip connection torque specification is 16 lb.-in. max. The minimum wire size is AWG#12. Consult the applicable electrical codes for your location for exact wire specifications. The power terminal connections are intended for copper wire only. This unit will work on either single or three phase power. Any dimmer channel may get power from any phase.

LOAD CONNECTIONS

The AT Series dimmer is a triac based dimmer meant for forward phase loads. You can connect up to 2400 Watts of lighting to each channel. Connect lighting loads to the upper terminal strip positions as indicated by the label in the unit (see Figure 1). The neutral bar and ground lug should be used for lighting loads. The terminal strip connection torque specification is 16 lb.-in. max.

PRESET CONTROLS

The AT Series dimmer provides a user interface on the circuit board as well as simple contacts to activate preset scenes. Almost any available low voltage wire may be used since these connections are just contact closures.

DMX CONTROLS

DMX control signals to the AT402 should be transmitted over a shielded twisted pair, low capacitance cable. The DMX bus should be daisy chained to all receiving units. It should NOT be connected in a star arrangement with multiple "home runs".

**DMX CABLE
CONDUCTOR ARRANGEMENT FOR
TWISTED PAIR, SHIELDED CABLE**

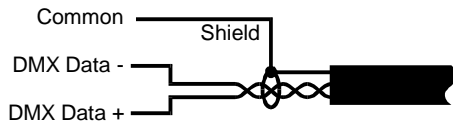

DMX TERMINATION

A DMX bus should be terminated (only) at the last receiving device on the chain. This is done by connecting a 120 ohm, 1/4 watt resistor across the DMX DATA - and DMX DATA + terminals.

FIGURE 2

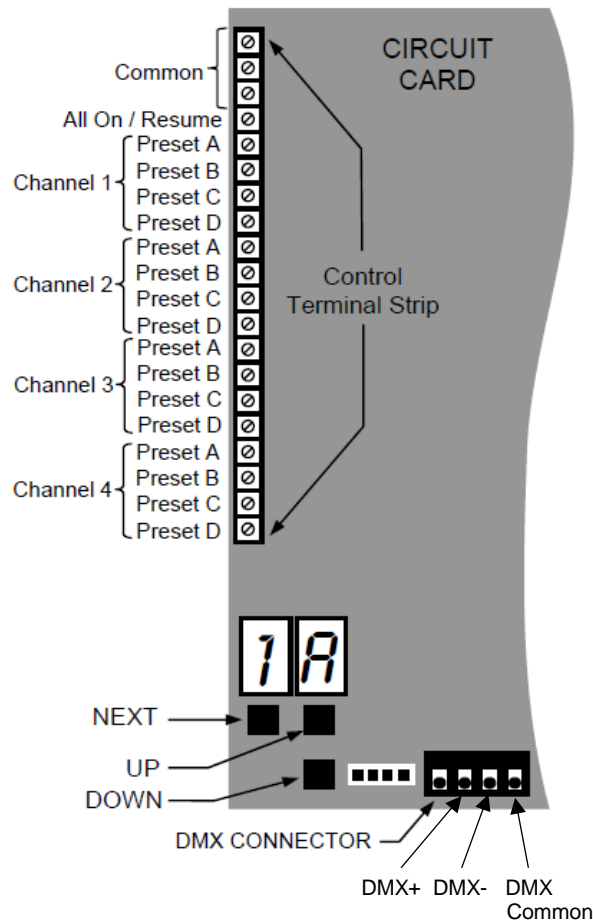

INITIAL SET UP

Set up of the AT Series dimmer is done using the two LED displays and the three push buttons located at the bottom left corner of the low voltage section of the circuit board inside of the unit. Use these controls to set the unit to match the type of input power being applied to the unit.

Set the Input Power Phase for each dimmer channel. This must be set correctly or dimming will not function properly.

Symbol	Function	Value
P2	Ch. 2 Input Phase	A, B, or C
P3	Ch. 3 Input Phase	A, B, or C
P4	Ch. 4 Input Phase	A, B, or C

For P2-P4, set to A, B, or C depending on which phase each channel gets its power from. For single phase power set P2, P3, and P4 to "A".

SINGLE PHASE POWER INSTALLATION

Press the **NEXT** button repeatedly until **P2** appears on the LED display. This tells the unit which phase circuit 2 is getting its power from, hence P2 (phase - Channel 2). Use the **UP/DOWN** buttons to set the right hand display to "A". Do the same for P3 and P4 (phase - Channel 3) (phase - Channel 4).

THREE PHASE POWER INSTALLATION

Press the **NEXT** button until **P2** appears on the LED display. Use the **UP/DOWN** buttons to set the right hand display to "B" or "C". If the unit does not fade smoothly between preset levels or some of the channels seem to operate in an OFF/ON only fashion, then you should change this setting to the other three phase choice (B or C).

OPERATION

CIRCUIT BREAKERS

AT Series dimmers use a 20 Amp magnetic circuit breaker for each dimming channel located on the right side of the unit. To operate a channel, the associated circuit breaker must be closed. Channel numbers for the circuit breakers are labeled on the unit. If a circuit breaker will not remain closed then there is an overload for that channel. This **MUST** be corrected before operation can continue.

LED INDICATORS

There is a green LED indicator for each channel on the circuit board. These represent the current lighting intensity for the associated channel. The red LED indicator is lit brightly when a DMX signal is present or if the ALL ON feature is active.

DIMMING CURVE

Dimming curves can be set independently for each of the available channels in an AT series unit. LL= LED (Lutron LED or IN=Incandescent). To set the dimming curve, press **NEXT** until you see c1. Use the **UP/DOWN** buttons to select LL or IN. Repeat on c2-c4 for each channel.

DMX OPERATION

The DMX channels are set by selecting the start address. The address is set on two separate menus **dH** for the hundreds position (0-5, 0 represents any address lower than 100) and **dL** for the ten's and one's position (0-99). To set the DMX address press the **NEXT** button until **dH** appears on the LED DISPLAY. Set the **dH** value to the first digit of the 3 digit address using the **UP/DOWN** buttons. Then press the **NEXT** button again or until you see **dL**. Set the **dL** value to the last two digits of the DMX address using the **UP/DOWN** buttons.

EXAMPLE: Start address of DMX 509 dH=05 dL=09

Note: When a valid DMX signal is present, the remote switch inputs will be disabled.

Loss of DMX: If there is a loss of DMX control signal during operation, the AT Series dimmer will revert back to the last active preset until DMX operation returns.

MANUAL PRESET OPERATION

GENERAL REMOTE SWITCH OPERATION - A SMALL THEATER EXAMPLE

During theater operation, the lighting is controlled by external momentary switch closures either manually or by automated equipment. The AT Series dimmer is designed to activate preset lighting conditions in response to these controls. A simple scenario is described in the following table. The table is for an installation where a four channel unit is used. The AT-402 dimmer channels 1 and 2 are connected to the house lights and AT-402 dimmer channels 3 and 4 are connected to the stage lights.

www.lightronics.com

REMOTE SWITCH CONNECTIONS EXAMPLE

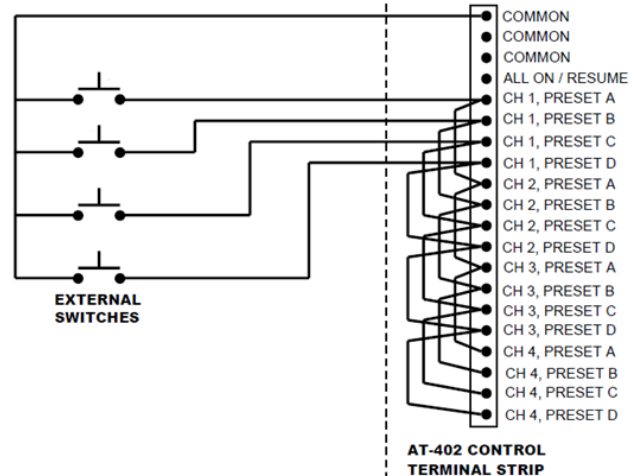

ACTIVITY or PRESET	HOUSE LIGHTING Channel 1	HOUSE LIGHTING Channel 2	STAGE LIGHTING Channel 3	STAGE LIGHTING Channel 4
A Opening and Seating	90% (5 sec. fade)	90% (5 sec. fade)	90% (5 sec. fade)	90%(5 sec. fade)
B Introduction	50% (15 sec. fade)	50% (15 sec. fade)	0% (15 sec. fade)	0% (15 sec. fade)
C Main Performance	0% (5 sec. fade)	0%(5 sec. fade)	0%	0%
D Closing	60% (10 sec. fade)	60% (10 sec. fade)	0%	0%

MANUAL ALL ON / RESUME OPERATION

The "All On / Resume" control may be activated by momentary external switch closure between one of the "Common" terminals and the "All On / Resume" terminal of the circuit board Control Terminal Strip. This function overrides all other switched channel controls and DMX input. It sets all channels to maximum intensity and remains in effect until the button is pushed again. At that time, the unit will "Resume" normal operation (return to the intensity settings provided by the other remote switch control signals).

FULL PROGRAMMING MENU STEPS

The LED's will alternate between the SYMBOL (channel/preset level and preset fade) and its VALUE (intensity and fade time). There are 2 digits and 3 buttons to control everything. Press the **NEXT** button to advance through each SYMBOL. Press the **UP** and **DOWN** buttons to change the VALUE for the alternately displayed SYMBOL.









AT SERIES ARCHITECTURAL DIMMER

INDIVIDUAL CHANNEL PRESET INTENSITY

100% intensity on the LED display is indicated by "FL".

SYMBOL	FUNCTION	VALUE
1A	Channel 1 Preset A intensity	0-100% intensity
1b	Channel 1 Preset B intensity	0-100% intensity
1C	Channel 1 Preset C intensity	0-100% intensity
1d	Channel 1 Preset D intensity	0-100% intensity
2A	Channel 2 Preset A intensity	0-100% intensity
2b	Channel 2 Preset B intensity	0-100% intensity
2C	Channel 2 Preset C intensity	0-100% intensity
2d	Channel 2 Preset D intensity	0-100% intensity
3A	Channel 3 Preset A intensity	0-100% intensity
3b	Channel 3 Preset B intensity	0-100% intensity
3C	Channel 3 Preset C intensity	0-100% intensity
3d	Channel 3 Preset D intensity	0-100% intensity
4A	Channel 4 Preset A intensity	0-100% intensity
4b	Channel 4 Preset B intensity	0-100% intensity
4C	Channel 4 Preset C intensity	0-100% intensity
4d	Channel 4 Preset D intensity	0-100% intensity

INDIVIDUAL CHANNEL FADE TIMES. You can STOP HERE, or continue and set the individual CHANNEL up/down fade times. (Applies to all presets).

SYMBOL	FUNCTION	VALUE
1 	Channel 1 Up fade time	1-99 seconds
1 	Channel 1 Down fade time	1-99 seconds
2 	Channel 2 Up fade time	1-99 seconds
2 	Channel 2 Down fade time	1-99 seconds
3 	Channel 3 Up fade time	1-99 seconds
3 	Channel 3 Down fade time	1-99 seconds
4 	Channel 4 Up fade time	1-99 seconds
4 	Channel 4 Down fade time	1-99 seconds

INDIVIDUAL PRESET UP/DOWN FADE TIMES

These settings will over-ride the fade up/down settings in the previous section. If individual preset fade times do not need to be set, then skip these steps. (Decimal indicates 1st option, not seen on AT menu itself).

SYMBOL	FUNCTION	VALUE
.A1	Chan. 1 Preset A up fade time	1-99 seconds
A1	Chan. 1 Preset A down fade time	1-99 seconds
.b1	Chan. 1 Preset B up fade time	1-99 seconds
b1	Chan. 1 Preset B down fade time	1-99 seconds
.C1	Chan. 1 Preset Cup fade time	1-99 seconds
C1	Chan. 1 Preset C down fade time	1-99 seconds
.d1	Chan. 1 Preset D up fade time	1-99 seconds
d1	Chan. 1 Preset D down fade time	1-99 seconds
.A2	Chan. 2 Preset A up fade time	1-99 seconds
A2	Chan. 2 Preset A down fade time	1-99 seconds
.b2	Chan. 2 Preset B up fade time	1-99 seconds
b2	Chan. 2 Preset B down fade time	1-99 seconds
.C2	Chan. 2 Preset Cup fade time	1-99 seconds
C2	Chan. 2 Preset C down fade time	1-99 seconds
.d2	Chan. 2 Preset D up fade time	1-99 seconds
d2	Chan. 2 Preset D down fade time	1-99 seconds
.A3	Chan. 3 Preset A up fade time	1-99 seconds
A3	Chan. 3 Preset A down fade time	1-99 seconds
.b3	Chan. 3 Preset B up fade time	1-99 seconds
b3	Chan. 3 Preset B down fade time	1-99 seconds
.C3	Chan. 3 Preset Cup fade time	1-99 seconds
C3	Chan. 3 Preset C down fade time	1-99 seconds
.d3	Chan. 3 Preset D up fade time	1-99 seconds
d3	Chan. 3 Preset D down fade time	1-99 seconds
.A4	Chan. 4 Preset A up fade time	1-99 seconds
A4	Chan. 4 Preset A down fade time	1-99 seconds
.b4	Chan. 4 Preset B up fade time	1-99 seconds
b4	Chan. 4 Preset B down fade time	1-99 seconds
.C4	Chan. 4 Preset Cup fade time	1-99 seconds
C4	Chan. 4 Preset C down fade time	1-99 seconds
.d4	Chan. 4 Preset D up fade time	1-99 seconds
d4	Chan. 4 Preset D down fade time	1-99 seconds

AT SERIES ARCHITECTURAL DIMMER

Version 0.3

OWNER'S MANUAL

11/23/2022

OPERATIONAL SETTING OPTIONS

SYMBOL	FUNCTION	VALUE
P2	Channel 2 Phase	A, B or C
P3	Channel 3 Phase	A, B or C
P4	Channel 4 Phase	A, B or C
c1	Channel 1 Curve	LL or IN*
c2	Channel 2 Curve	LL or IN*
c3	Channel 3 Curve	LL or IN*
c4	Channel 4 Curve	LL or IN*
dH	Start DMX address - Hundreds	0-5
dL	Start DMX address - Tens/Ones	0-99

* Lutron LED or Incandescent

MODEL NUMBERS AND CONFIGURATION

The table below shows the number of channels for each model number.

An additional suffix may also appear in the model number. This suffix is "/2" and indicated that the unit is for 230VAC applications.

For one and two channel versions, only the components, indicators, and connection points for the applicable channels will be present in the unit.

MODEL NUMBER	DESCRIPTION
AT-402	4 Channels
AT-202	2 Channels
AT-102	1 Channel

MAINTENANCE

WARNING!

RISK OF ELECTRICAL SHOCK

There are lethal voltages present in this product when power is applied to its feed circuits. The cabinet should be opened only by a qualified electrician.

WARNING!

RISK OF ELECTRICAL SHOCK

Make sure that all power is removed from feed circuits before changing the fuse.

The only user servicable part in the AT Series dimmer is the Type ABC, ½ Amp, 250 Volt, fast acting fuse. The fuse may be replaced ONLY with an identical fuse.

Service by other than the manufacturer's authorized agents may void your warranty. If service is required, contact the dealer from whom you purchased the dimmer, or Lightronics, Service Department, 509 Central Drive, Virginia Beach, VA 23454. Tel: 757 486 3588.

The best way to prolong the life of your unit is to keep it cool, clean, and dry. It is important that the cooling intake and exit vent holes are clean and unobstructed.

Lightronics recommends that you record the serial number of your AT402 for future reference.

SERIAL NUMBER _____

WARRANTY INFORMATION AND
REGISTRATION - CLICK LINK BELOW

www.lightronics.com/warranty.html