

## RD121

### RACK MOUNT DIMMER

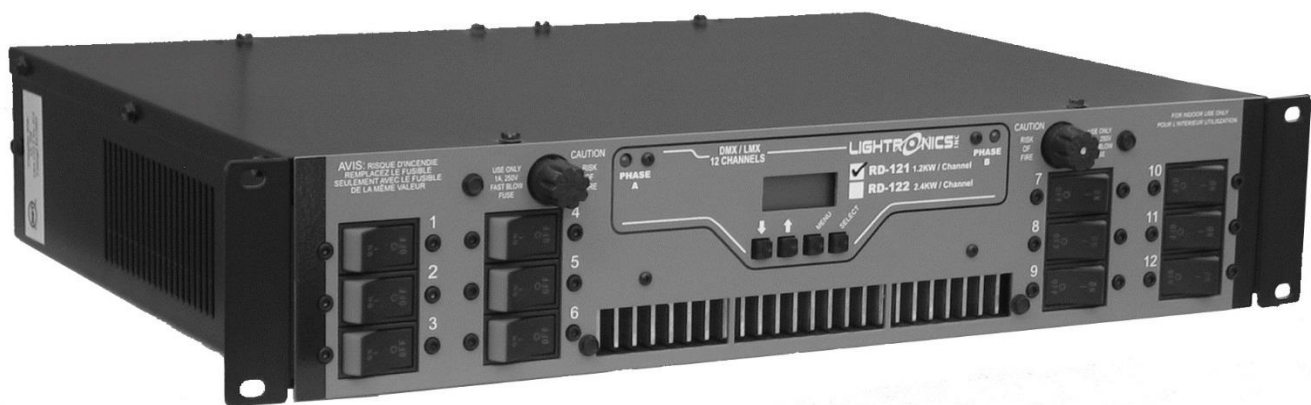

### OWNER'S MANUAL

VERSION 1.4

02/17/2022

## RD121 RACK MOUNT DIMMER OWNER'S MANUAL

Version 1.4

02/17/2022

### UNIT DESCRIPTION AND FUNCTIONS

The RD121 is a 14,400 Watt, 12 channel, rack mountable dimmer. Each of the channels has a capacity of 1200 Watts. It is controlled via low voltage signals which may be LMX-128 (3 wire multiplex) or USITT DMX-512. The unit is fan cooled. Channels may be independently assigned from the unit. The unit is over temperature protected and has a magnetic circuit breaker for each channel. There are five options for channel output connection panels. Options include: Duplex outlet panel with 1 connection per channel, External terminal strip (includes knockout cover), Stagepin panel with 1 connection per channel, Patchbay panel with 2 powerlock connections per channel and Socapex connector panel (wiring per customer selection). The RD121 has several stand alone functions which enable it to operate without a control console. These functions include a storable scene which may be activated by an external switch closure, a programmable chaser and 7 factory set chase patterns.

### POWER REQUIREMENTS

Each RD121 requires both hots from a SINGLE PHASE 120/240 VOLT AC or TWO PHASES OF A THREE PHASE 120/208 VOLT AC service. The neutral conductor is shared by two hots so it is important the two hots used are of different phases. EACH PHASE must be capable of providing 60 AMPS. Line frequency is typically 60HZ. A 50HZ model is available for export. Refer to the dimmer electrical rating markings to determine the operating frequency. One or more RD121 dimmers may be installed into a standard 19" equipment rack with provisions for connection to an appropriate electrical service in accordance with the National Electrical Code.

### INSTALLATION

#### PLACEMENT

The RD121 is designed to be mounted in a standard 19" equipment rack using the four mounting holes in the face plate of the dimmer. If the dimming system will be used for touring shows, it is recommended you provide additional support for the rear of the unit. The dimmer is fan cooled and requires no space between units when multiple dimmers are used. Air enters the dimmer through slots on the side and exits through holes in the bottom of the face plate. Make certain these ventilation holes are

not obstructed. Do not place the RD121 where it will be exposed to moisture or excessive heat. The RD121 is intended for INDOOR USE ONLY.

#### POWER CONNECTIONS

### WARNING



**MAKE CERTAIN POWER IS  
REMOVED FROM THE FEED  
CIRCUITS BEFORE YOU BEGIN  
INSTALLATION.**



Consult your local electrical codes to determine the proper wire type and wiring methods for your installation.

Power enters the RD121 through a knockout sized for 1" conduit at the rear of the unit. Remove the top cover and install an appropriate cable clamp in the knockout hole. Pass the power cables through the hole. Behind the hole is a terminal block with three lugs. The connections labeled "H1" and "H2" are the line connections or "hots". The center connection labeled "N" is the neutral. There is an additional lug labeled "G" to the right of the terminal block. This is for connecting the unit to earth ground. When connections are completed, reinstall the cover and tighten the cable clamp.

#### OUTPUT CHANNEL CONNECTIONS

The RD121 can be supplied with one of several rear panel output options. Channel output connections are according to the rear panel selected. Channel connections generally proceed from left to right (if you are facing the rear of the unit). Channel "1" will be on the left end. On a unit supplied with edison plug outlets, channels 1 - 6 are on the top row (from left to right). Channels 7 - 12 are on the lower row (from left to right). Connections for load Neutrals are provided. There is also a ground lug terminal to be used for your load circuit grounds.

#### CONTROL SIGNAL CONNECTIONS (Units with DB9 connectors)

A control signal enters the RD121 through connectors on the rear of the unit. If you are using the 3 pin multiplex protocol ("LMX" or compatible), plug the control cable into the 3 pin "XLR" connector. If you are using the DMX-512 protocol, plug your 5 pin DMX control cable into the 5 pin to 9 pin adapter supplied with the RD121 and plug the 9 pin connector into the upper 9 pin connector on the rear of the dimmer. In either case, the lower 9 pin connector and the ribbon cable jumper that is

**RD121 RACK MOUNT DIMMER  
OWNER'S MANUAL**

Version 1.4

02/17/2022

supplied can be used to connect from the lower connector of the first dimmer into the upper connector of the next dimmer and so on. See the included drawings at the back of this manual for clarification. The RD121 is shipped with the power supply set to provide +15 volts DC console power when using the 3 pin multiplex protocol. Note the DMX-512 protocol does NOT provide a means for console power via the control cable. Systems using the DMX protocol must have console power supplied by other means.

**CONTROL SIGNAL CONNECTIONS (Units with 5 pin DMX & 7 pin Phoenix connector)**

A control signal enters the RD121 through connectors on the rear of the unit. You can plug the 5 pin control cable into the 5 pin XLR connector or connect individual wires into the 7 pin Phoenix connector. Connections to additional DMX devices can be made via the lower 5 pin XLR connector or into the 7 pin Phoenix connector. See the included drawings at the back of this manual for clarification.

**SETUP**

The RD121 has a front panel LCD display and operator controls. The display indicates dimmer status information and is used with the operator control buttons to set up and monitor dimmer operation. A menu system is used to access the various features of the RD121. During normal dimmer operation the display shows the current intensity setting for each channel and indicates what type of dimmer control is in effect. This is called the STATUS DISPLAY and is shown in the diagram below.

**STATUS DISPLAY AND OPERATOR CONTROLS**

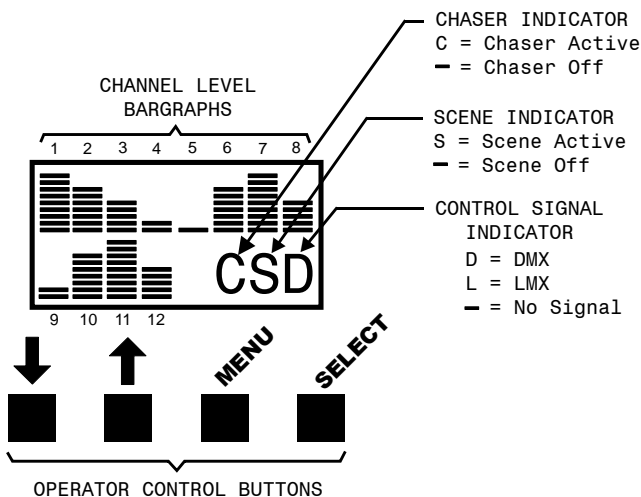

www.lightronics.com

**RESETTING THE UNIT**

The RD121 may be reset to a "factory provided" configuration by holding down the **MENU** button on the front panel for about 5 seconds. A message "SYSTEM RESET" will appear on the front panel LCD display. Release the **MENU** button when you see the message. Resetting the unit causes the following actions:

1. Channel patch is set to 1 to 1.
2. All channels are set to DMR (relay mode turned off).
3. The external switch sensing function is turned off.
4. The internally stored scene is turned off. (it is not erased).
5. The programmable chase pattern is turned off and erased.
6. Chase parameters are set to a default set of conditions. The Default conditions are given in the table under the section CONTROLLING CHASER CHARACTERISTICS.

You should perform a setup procedure before using the unit. Setup includes (1) Setting the channel assignments the dimmer will respond to and (2) Setting individual channels to "DMR" or "RLY" (relay). Once the setup is completed the unit will retain the settings until changed by the operator (including when the unit is powered off and restarted).

**ASSIGNING DIMMER CHANNELS (CHANNEL PATCHING)**

The RD121 has 12 dimming channels labeled 1-12. Each of these channels may be assigned to any console channel number from 1 to 512. Multiple dimmer channels may be assigned to a single console fader if desired. This gives you the ability to soft patch at the dimmer itself.

**TO ASSIGN DIMMER CHANNELS:**

1. Press the **MENU** once to enter the patch mode. The display will indicate "PTCH".
2. Push **SELECT**. The left display bar graph channel (for dimmer channel A) will flash and the currently assigned console channel will be shown on the display bottom row. Use the **UP** and **DOWN** arrow buttons to change the console channel assignment for channel 1.
3. Push **SELECT** to advance to the next dimmer channel. Continue to assign channels through channel 12.

**RD121 RACK MOUNT DIMMER**

Version 1.4

**OWNER'S MANUAL**

02/17/2022

4. Push **MENU** three times to return to the normal operation mode.

TO SET CHANNELS TO DIM OR NON-DIM (RELAY):

1. Press **MENU** twice. The LCD display will indicate "NDIM".
2. Push **SELECT**. The left display bar graph channel (for dimmer channel 1) will flash. The display will show "DMR" or "RLY" on the bottom row according to the current setting.
3. Use the **UP** and **DOWN** arrow buttons to change between dimmer and relay modes for that channel.
4. Push **SELECT** to advance to the next dimmer channel. Continue to set channels through channel 12.
5. Press **MENU** twice to return to the normal display.

**MANUAL OPERATION**

Dimmer channels can be operated manually from the dimmer front panel. Press the **SELECT** button until the desired channel's "bar graph" is flashing. Press the **UP** or **DOWN** arrow buttons until the desired level is reached. Press the **SELECT** button to advance to other channels. To return control to your console, press the **SELECT** button until you go PAST the last channel and stop. After approximately 6 seconds the dimmer will return to console control. A channel continues to respond to console settings when operating from the front panel unless you change the level for that channel at the dimmer front panel. Once this occurs - that channel will NOT respond to console settings until you return to normal console control.

**NORMAL OPERATION**

As you operate faders on your console, the associated channel levels are indicated on the RD121 display. The display will also indicate any abnormal conditions such as over temperature. The fan will run at full speed whenever there is a control signal present and one or more faders are at full on. The fan will drop to half speed a few minutes after all faders are lowered to full off and will stop shortly after the control signal is removed.

**INTERNAL SCENE OPERATION**

The RD121 has the ability to internally save a single scene which may be activated remotely. The scene

remains in the unit's memory when it is shut off and will be available the next time the unit is powered on. A saved scene is not lost when the unit is reset.

TO SAVE A SCENE:

1. Create the scene from a control console or from the front panel of the dimmer itself by activating the applicable channels.
2. Press and hold the front panel **SELECT** button until you see the front panel display appears as shown below (You will have to hold the button down for about 6 seconds):

**Scene  
Save #01**

3. Push **SELECT**. The display will show the message:

**SAVING  
NOW !**

4. The scene has been recorded when the LCD reverts to its normal display.

TO ACTIVATE A STORED SCENE:

A scene previously stored in the RD121 is activated by connecting together Switch Input & Switch Common (Pins 6 and 7 of the 7-pin Phoenix connector or pins 5 and 9 of either DB9 connector depending on the rear plate design). The connectors are on the rear of the dimmer. This may be done via a remotely located switch. The activated scene will remain active as long as a closed circuit is maintained between these pins.

In addition to activating a scene, the RD121 can be set to ignore the remote switch or activate chaser functions. In order to use the remote switch for internal scene activation you must enable that function as follows:

1. Push **MENU** 3 times. The display will show the message "MENU" on the bottom row.
2. Push **SELECT**. The LCD will display one of the messages shown below.

**Input1  
Scene**

**Input1  
Chaser**

**Input1  
Not Used**

3. If "Not Used" or "Chaser" appears on the bottom row, push the **UP** or **DOWN** until "Scene" appears.

## RD121 RACK MOUNT DIMMER OWNER'S MANUAL

Version 1.4

02/17/2022

4. Push **SELECT** to return the unit to normal operation.

The front panel display shows an "S" on the bottom row as an indication that an internal scene is active.

### NOTES ABOUT INTERNAL SCENE

The RD121 continues to respond to control console signals when the internal scene is activated. The intensity of any given channel will be the "greatest of" or "pile on" result of the internal scene and console level setting.

If multiple RD series dimmers are connected as a system (See CONTROL SIGNAL CONNECTIONS), then a remote switch connected to the system can activate system wide scenes or only scenes in specific dimmers depending on how the remote switch function is set in each dimmer. These scene features give you the ability to use the dimmer for house lights and other applications where it is not practical to operate a control console.

### CHASER OPERATION

The RD121 can operate chaser functions as a "stand alone" unit with no control console present. There are 7 factory set chase patterns embedded in the unit software. There is also one pattern which may be programmed by the user. The chase step rate, chase step fade rate and chase intensity can be set by the user for all chaser functions. Chaser functions may be set to run continuously or as a single occurrence. The number of steps (up to 32) can be set for the programmable chase. The RD121 may be set to begin chaser functions at "power up" or in response to a remote switch. A bounce option can be imposed on a chase pattern. This results in a pattern which runs in its normal sequence then runs the same sequence backwards.

### ACTIVATING A CHASE PATTERN

A chase stored in the RD121 is activated by connecting together Switch Input and Switch Common (Pin 6 and 7 of the 7-pin Phoenix connector or pins 5 and 9 of either DB9 connector depending on the rear plate design). The connectors are on the rear of the dimmer. This may be done via a remotely located switch. The activated chase will remain active as long as a closed circuit is maintained between these pins.

In addition to activating a chase, the RD121 can be set to ignore the remote switch or use it to activate a

[www.lightronics.com](http://www.lightronics.com)

scene. In order to use the remote switch to activate chase patterns you must enable that function as follows:

1. Push **MENU** 3 times. The display will show the message "MENU" on the bottom row.
2. Push **SELECT**. The LCD will display one of messages shown below.

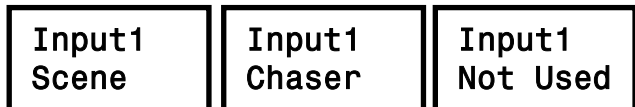

3. If "Not Used" or "Scene" appears on the bottom row, push the **UP** or **DOWN** arrow buttons until "Chaser" appears.
4. Push **SELECT** to return the unit to normal operation.

The Front panel display shows a "C" on the bottom row as an indication that an internal chase is active.

### SELECTING A CHASE PATTERN

You can select any of the 7 factory preset chase patterns to run or create and run your own custom pattern. Instructions for creating a custom chase pattern are given further on in this manual.

A chase pattern is selected using the RD121 menu system as follows:



1. Push **MENU** 3 times. The LCD will appear as shown:

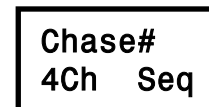

2. Push **SELECT**. Then push **MENU**. The LCD will appear as shown: The bottom display row shows the currently selected pattern. The pattern "4Ch Seq" is shown as an example.
3. Use the **UP** and **DOWN** arrow buttons to scroll through the available chase patterns. Push **SELECT** when the desired pattern appears.

Note: Remember this action does not activate the chase pattern. This action selects which pattern will be run when activated by the remote switch function.

**RD121 RACK MOUNT DIMMER  
OWNER'S MANUAL**

Version 1.4

02/17/2022

The available patterns are:

4 CHANNEL SEQUENCE	8 CHANNEL SEQUENCE
4 CHANNEL BUILD	12 CHANNEL SEQUENCE
6 CHANNEL SEQUENCE	RANDOM
6 CHANNEL BUILD	PROGRAMMABLE

**CONTROLLING CHASER CHARACTERISTICS**

You can control seven characteristics of a chase pattern. These controls are described as follows:

Chase Rate	The duration of each chase step (.25 - 999.75 seconds). Default = 1 Second
Chase Fade Rate	The time for each step to reach maximum intensity (0 - 100% of step time). Default = 100%
Chase Intensity	The overall brightness of the chase (0 - 100%) Default = 100%
Chase Steps	The maximum number of steps in the chase (1 - 32) Default = 4
Chase Bounce	Causes reversal at the end of each sequence (Ignored during RANDOM). Default = Off
Continuous /Single	Enables/Disables a "one shot" chase occurrence (Ignored during RANDOM). Default = Continuous
Activate Chase at power up	Enables chase to begin automatically when dimmer is turned on. ** Default = Off

\*\*Overrides remote switch setting.

The default setting is the factory set value.

All of these characteristics can be set via the RD121 menu system. See the diagram STRUCTURE OF MENU SYSTEM for a complete layout of menu system operation.

**CREATING YOUR OWN CUSTOM CHASE PATTERN**

The programmable chase pattern is created by setting the intensity for all dimmer channels for each step in the chase. The chase step is then recorded.  
www.lightronics.com

This action is then repeated for each additional step to be recorded. The channel intensities can be set either from the RD121 front panel as in manual operation or by using a control console.

**TO SAVE A CHASE STEP:**

1. Create the step from a control console or from the front panel of the dimmer itself by activating the applicable channels. Channel intensities are recorded as either full ON or full OFF. If you want a given channel to be on for a chase step then the channel must be set to greater than 50 % intensity. Note the overall intensity of the whole chase pattern may be set using the menu system.
2. Press and hold the front panel **SELECT** button until the front panel display appears as shown below (You will have to hold the button down for about 6 seconds):

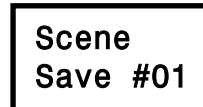

3. Push the **UP** arrow button. The display will appear as follows:

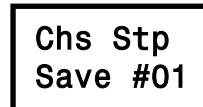

This is the display for chase step #1. If you want to record to another step number - use the **UP** and **DOWN** arrow buttons to make the correct step number appear on the lower display row.

4. Push **SELECT**. The display will show the message:



5. The chase step has been recorded when the LCD reverts to its normal STATUS DISPLAY.

The above recording process is repeated for each step in the programmable chase pattern. See the section CONTROLLING CHASER CHARACTERISTICS for information about how the chase can be made to appear when activated.

**RD121 RACK MOUNT DIMMER  
OWNER'S MANUAL**

Version 1.4

02/17/2022

**MAINTENANCE AND REPAIR****FRONT PANEL BREAKERS AND FUSES**

The RD121 has two fuses. The left fuse is 1 Amp. The right fuse is 1/4 Amp. Both are 250V, 1.25 x .25 inch, fast acting fuses. These fuses provide protection for the internal electronic control circuitry and the fan. They may be replaced **ONLY** by fuses of identical type and size.

Each channel of the RD121 is protected by a 10 Amp, fast acting, magnetic circuit breaker located on the front panel of the unit. If the total load for a channel is greater than 1200 Watts the channel circuit breaker will trip.

**TROUBLESHOOTING****VERIFY ALL POWER IS REMOVED FROM THE DIMMER BEFORE HANDLING THE UNIT.**

1. To simplify troubleshooting - reset the unit to provide a known set of conditions.
2. Check the console is powered and the console channels are correctly patched or set.
3. Check the control cable between the dimmer and console.
4. Verify the loads and their connections.

**OWNER MAINTENANCE**

There are no user serviceable parts inside the unit.

The best way to prolong the life of your unit is to keep it cool, clean, and dry. It is important the cooling intake and exit vent holes are clean and unobstructed.

Service by other than Lightronics authorized agents may void your warranty.

**OPERATING AND MAINTENANCE ASSISTANCE**

If service is required, contact the dealer from whom you purchased the equipment or contact Lightronics, Service Department, 509 Central Drive, Virginia Beach, VA 23454 TEL 757 486 3588. All items returned for service must include a description of the problem along with your name, address, and phone number.

Lightronics recommends you record the serial number of your unit for future reference.

**SERIAL NUMBER** \_\_\_\_\_

**WARRANTY INFORMATION AND  
REGISTRATION – CLICK LINK BELOW**

[www.lightronics.com/warranty.html](http://www.lightronics.com/warranty.html)

**RD121 RACK MOUNT DIMMER  
OWNER'S MANUAL**

Version 1.4

02/17/2022

**STRUCTURE OF MENU SYSTEM**

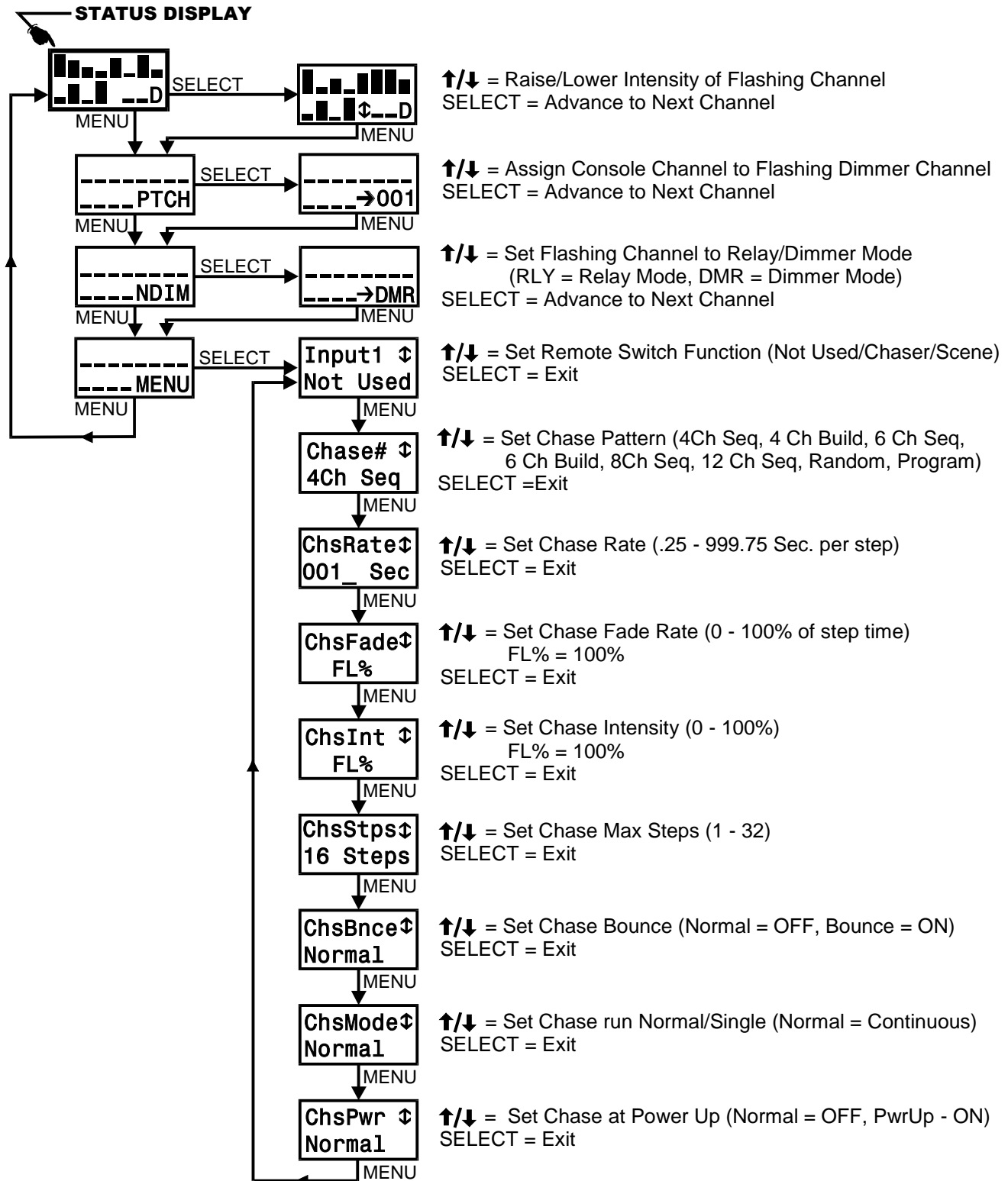



**RD121 RACK MOUNT DIMMER  
OWNER'S MANUAL**

**REAR PANEL CONNECTION OPTIONS  
DUPLIX OUTLET PANEL**

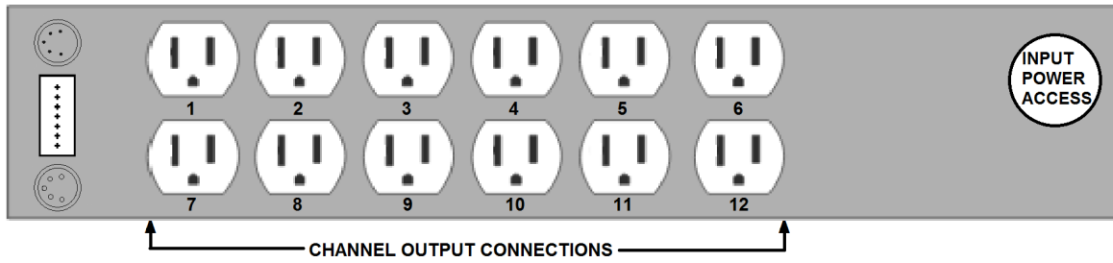

**EXTERNAL TERMINAL STRIP (includes knockout cover)**

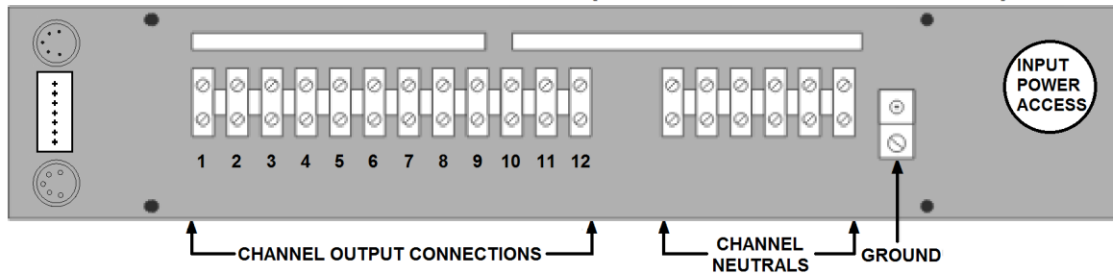

**STAGE PIN PANEL**

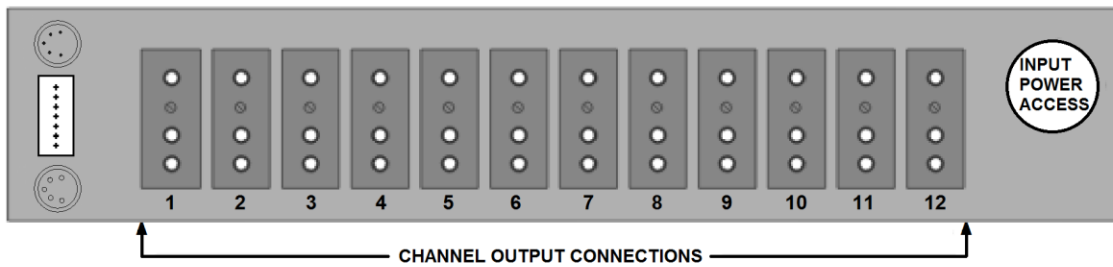

**PATCH BAY PANEL**

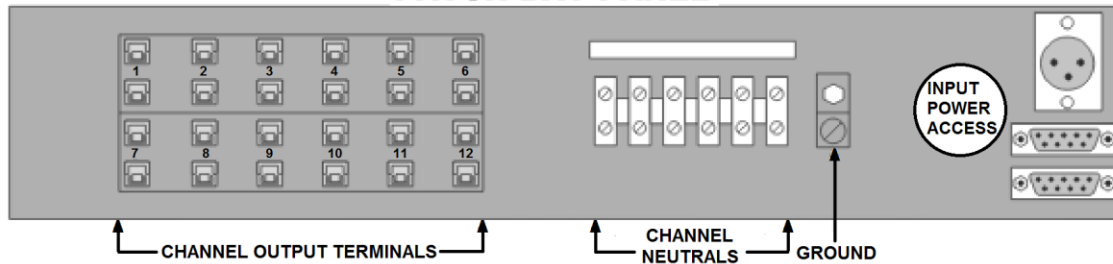

**SOCAPEX PANEL**

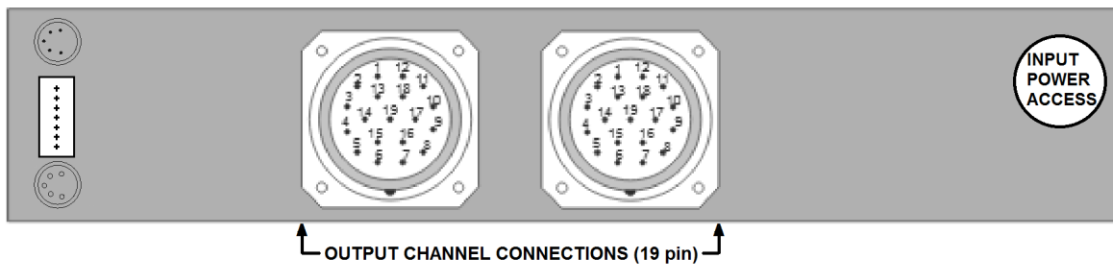

**RD121 RACK MOUNT DIMMER  
OWNER'S MANUAL**

Version 1.4

02/17/2022

**CONTROL SIGNAL CONNECTIONS  
FOR LMX PROTOCOL**

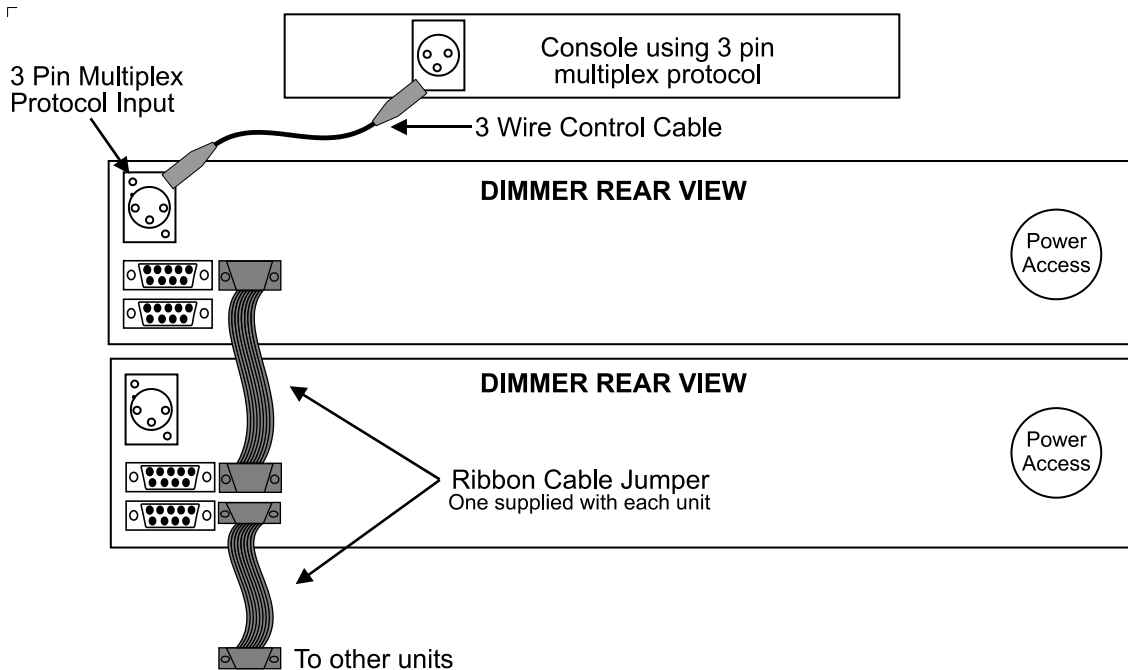

**CONTROL SIGNAL CONNECTIONS  
FOR DMX 512 PROTOCOL**

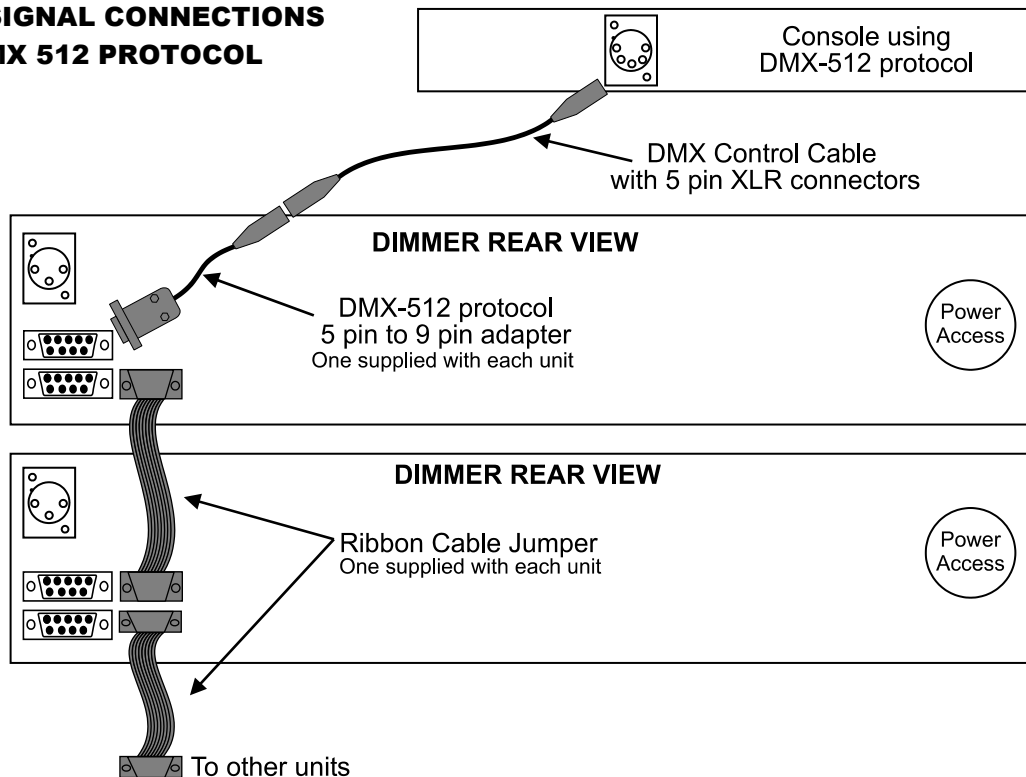

**RD121 RACK MOUNT DIMMER  
OWNER'S MANUAL**

Version 1.4

02/17/2022

**PIN ASSIGNMENTS OF CONTROL SIGNAL CONNECTORS USED ON THE RD121**

**5 PIN DMX**

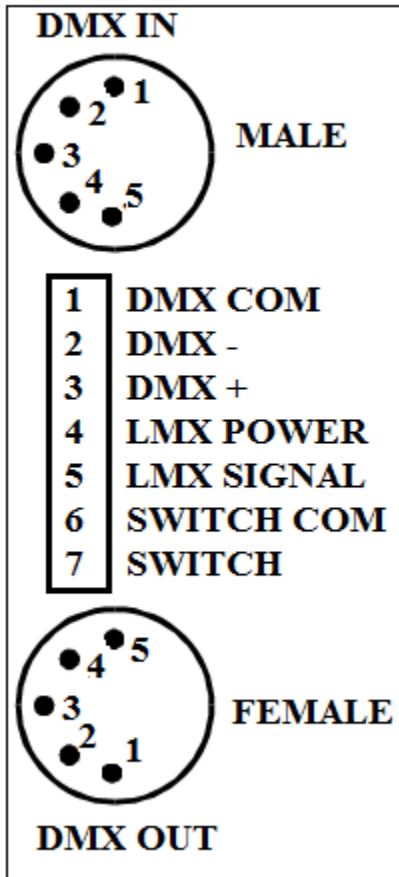

**3 PIN DMX**

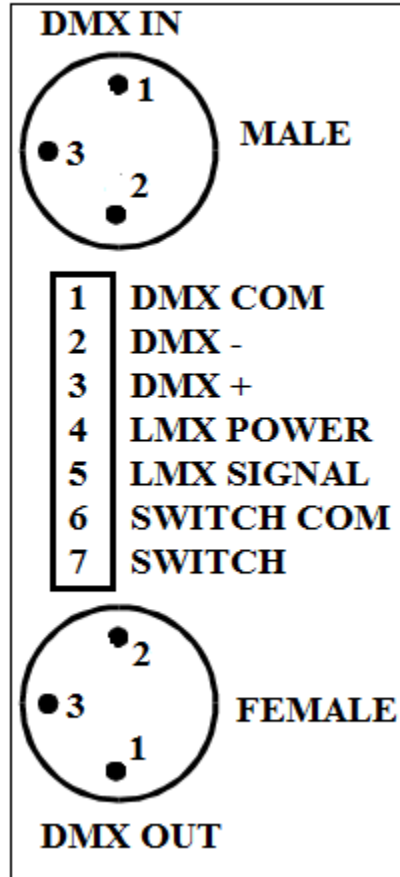

**3 PIN LMX**

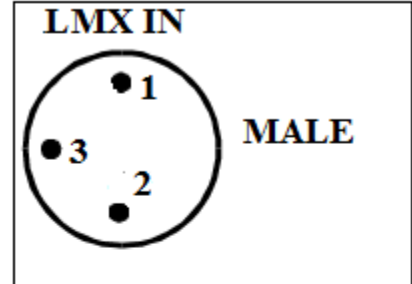

**9 PIN MALE (DB9)**

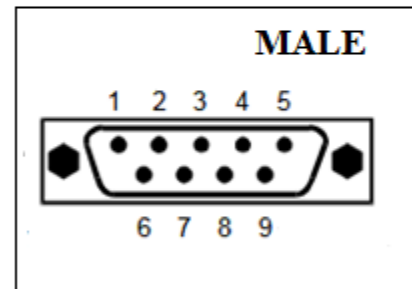

PIN #	3 PIN LMX	3 PIN DMX	5 PIN DMX	7 PIN PHOENIX	9 PIN DB9
1	LMX COMMON	DMX COMMON	DMX COMMON	DMX COMMON	LMX COMMON
2	LMX POWER	DMX DATA -	DMX DATA -	DMX DATA -	LMX POWER
3	LMX SIGNAL	DMX DATA +	DMX DATA +	DMX DATA +	LMX SIGNAL
4	-----	-----	NOT USED	LMX POWER	NOT USED
5	-----	-----	NOT USED	LMX SIGNAL	SWITCH COMMON
6	-----	-----	-----	SWITCH COMMON	DMX COMMON
7	-----	-----	-----	SWITCH INPUT	DMX DATA -
8	-----	-----	-----	-----	DMX DATA +
9	-----	-----	-----	-----	SWITCH INPUT