

**FEATURES AND SPECIFICATIONS**

LEDS: 36 Ten Watt LEDs (RGBW)  
 Beam angle: 45 °  
 Control system: DMX-512 + Stand Alone  
 DMX channels: 3, 4, 5, or 8  
 DMX connectors: 3 pin  
 Voltage: 100 - 250 VAC, 50/60Hz  
 Max power consumption: 400 Watts  
 IP Rating: IP 65  
 Body Size: 12 7/8"D x 10 7/8"W x 13 7/8"H  
 Body material: Die Cast Aluminum  
 Body color: Black  
 Weight: 28.7 lbs

**DESCRIPTION**

The FXLD1036C40 is a RGBW LED lighting fixture. It is suitable for stage, disco, night club, and other artistic applications. It has several stand alone control modes, a master/slave mode, and can operate via a DMX-512 external signal.

A double yoke enables the fixture to be operated in several positions.

**INSTALLATION**

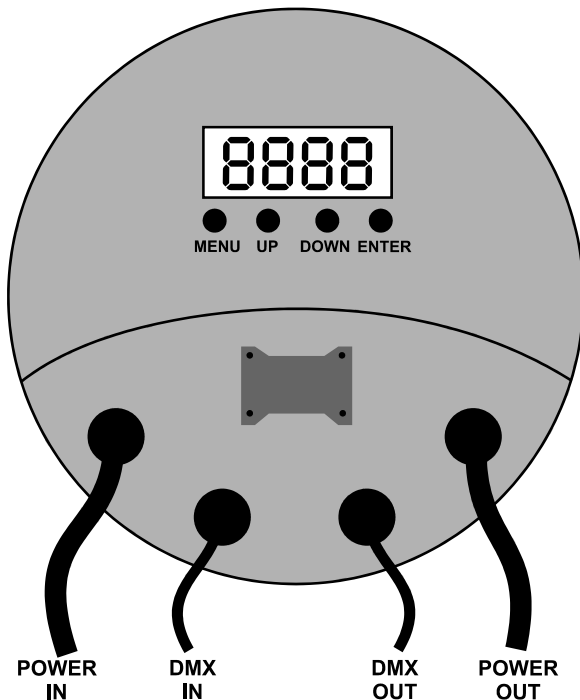

**LOCATION**



The FXLD1036C40 is rated IP65 and can be used outdoors. The maximum operating temp. is 104 deg F.

Locate the unit in a well ventilated area. The unit can be run in any position. **Keep the unit at least 18" from any flammable materials.**

Holes are provided on the yokes to install a lighting bar pipe clamp. Use a safety cable if hanging the fixture.

**POWER CONNECTIONS**

The FXLD1036C40 has a power input cable and a power adapter cable for connection to a 120 VAC, 15 Amp, 60Hz, grounded electrical service.

The unit also has a power output cable. This cable can be used to supply power to another nearby FXLD1036C40. You can power a **MAXIMUM** of 4 fixtures this way.

**The power cable ground terminals must be used.**

**DMX CONNECTIONS**

The FXLD1036C40 has permanent DMX in and DMX out cables. Two DMX adapter cables are also supplied to enable the use of 3 pin XLR connections.

A system using DMX control should be connected as a chain of devices. In other words the control signal cable should proceed from the controller to the first receiving device and then to others in a continuous "daisy chain" fashion. The control cable should NOT be split into a multiple run star arrangement with a cable running from the controller directly to each receiving device.

**DMX CONNECTOR PIN ASSIGNMENTS**

There are normally two different connectors used for DMX control. They are both XLR type connectors. Some units use 3 pin connectors. Others use 5 pin connectors. The FXLD1036C40 receives a DMX signal on the 3 pin MALE connector on one side of the unit. The 3 pin FEMALE connector is used to connect the next DMX device on the control chain. If your console uses a 5 pin connector you can make up an adapter cable to convert. The table below shows the pin assignments for BOTH the 3 pin and 5 pin connectors.

The permantly attached DMX in and DMX out cables are not XLR connectors but follow the same pin assignments as 3 pin XLRs.

IN #	SIGNAL NAME
1	DMX COMMON
2	DMX DATA -
3	DMX DATA +
4	NOT USED
5	NOT USED

**DMX TERMINATION**

A DMX chain should be terminated at the last receiving device on the chain. This is done by installing a commonly available 1/4 Watt, 120 Ohm resistor across the DATA - and DATA + wires at the last device. If you have only a few fixtures very close together and a very short run to the controller then you may be able to operate without the terminator.

**OPERATION**

A control panel on one side of the unit is used to set the operating options. It consists of an LED display and four buttons (MENU, UP, DOWN, and ENTER)

**CONTROL PANEL**

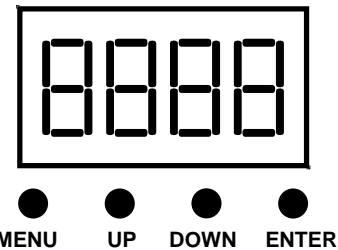

Push MENU to access the operating options. Then use UP and DOWN to scroll through the available choices. When you reach the option you want to set or change - push ENTER. Now you can view the current setting for the option and/or change it. Push ENTER to save your changes and activate the option. See the "MENU NAVIGATION" diagram for additional details.

There are 13 operating options: DMX address, Mode, White Level, Blue Level, Green Level, Red Level, Flash Sequence, Fade Sequence, Auto Sequence, Run Program, Program Speed, DMX Mode, and Slave Mode.

When the unit is powered on it begins operation in the state it was in when the power was last turned off.

**DMX ADDRESS SELECTION**

Use the Addr menu to set the starting address of the unit. You can set the starting address of the unit with the UP and DOWN buttons.

**DMX MODE SELECTION**

The FXLD1036C40 can operate using an External DMX signal in four different configurations (3 Channel, 4 Channel, 5 Channel, and 8 Channel)

Use the Chnd menu to select a DMX Mode.

Detailed channel operation in each of the four modes is given in the table "DMX VALUES AND FUNCTIONS".

**NODE SELECTION**

The node function is not currently supported.

**MANUAL OPERATION**

For manual operation the white, blue, green, and red LED intensity levels may be independently controlled. Use the UL - -, bL - -, gL - -, and rL - -, menus to set the levels. The range is from 00 (OFF) to 15 (Full On).

**FLASH OPERATION**

Flash mode is a continuous strobe of all LEDs. Use the FLAS menu to control the speed. The range is 00 - 15. 00 is fastest.

**FADE OPERATION**

Fade mode is a fading sequence of 8 colors. Use the FADE menu to control the speed. The range is 00 - 15. 00 is fastest.

**COLOR TEST**

The COLOR TEST mode switches continuously through a sequence of 14 colors. Use the CE - - menu to control the speed. The range is 00 - 15. 00 is fastest.

**PROGRAM RUN**

The unit can operate using 28 preset programs. Presets 1 through 13 are solid colors. The remaining presets are a variety of changing colors and patterns. Use the Pr - - menu to select and activate a preset program. The range is from 00 to 28.

**PROGRAM SPEED**

The speed of some of the PROGRAM RUN selections can be altered. Use the SP - - menu to set the speed. The range is 00 - 15. 00 is fastest.

**MASTER/SLAVE OPERATION**

The FXLD1036C40 can operate in a Master/Slave mode where one of the units can synchronize other units of the same model.

Connect the units together using the DMX IN and DMX OUT connectors. Set the unit to be the Master in one of the modes above. Use the SLAV menu to set a unit as a slave.

**PHOTOMETRIC CHARACTERISTICS**

Distance	Illuminance (Lux)	Beam Diameter.
10 ft	5840	8'
20 ft	1680	13'
30 ft	760	18'

**MAINTENANCE AND REPAIR**

**DISCONNECT ALL POWER AND CONTROL CABLES BEFORE HANDLING THE UNIT**

**TROUBLESHOOTING**

Check that you have power applied to the unit.

Check the DMX control cable.

Check the address settings of the unit and controller.

**CLEANING**

Do not use harsh chemicals or solvents when cleaning the fixture. A mild detergent can be used sparingly if needed. Ensure that the unit is completely dry before re-use.

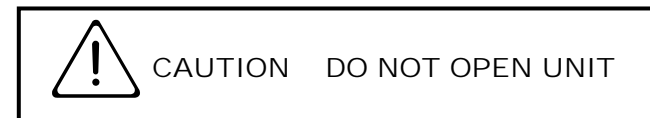
**REPAIR**

The FXLD1036C40 does not contain any parts which can be serviced by the user.

Internal service on the unit by other than Lightronics authorized agents will void the warranty.

If service is required, contact the dealer from whom you purchased the item, or contact the Lightronics, Service Department, 509 Central Drive, Virginia Beach, VA 23454. Tel: 757 486 3588.

MENU NAVIGATION

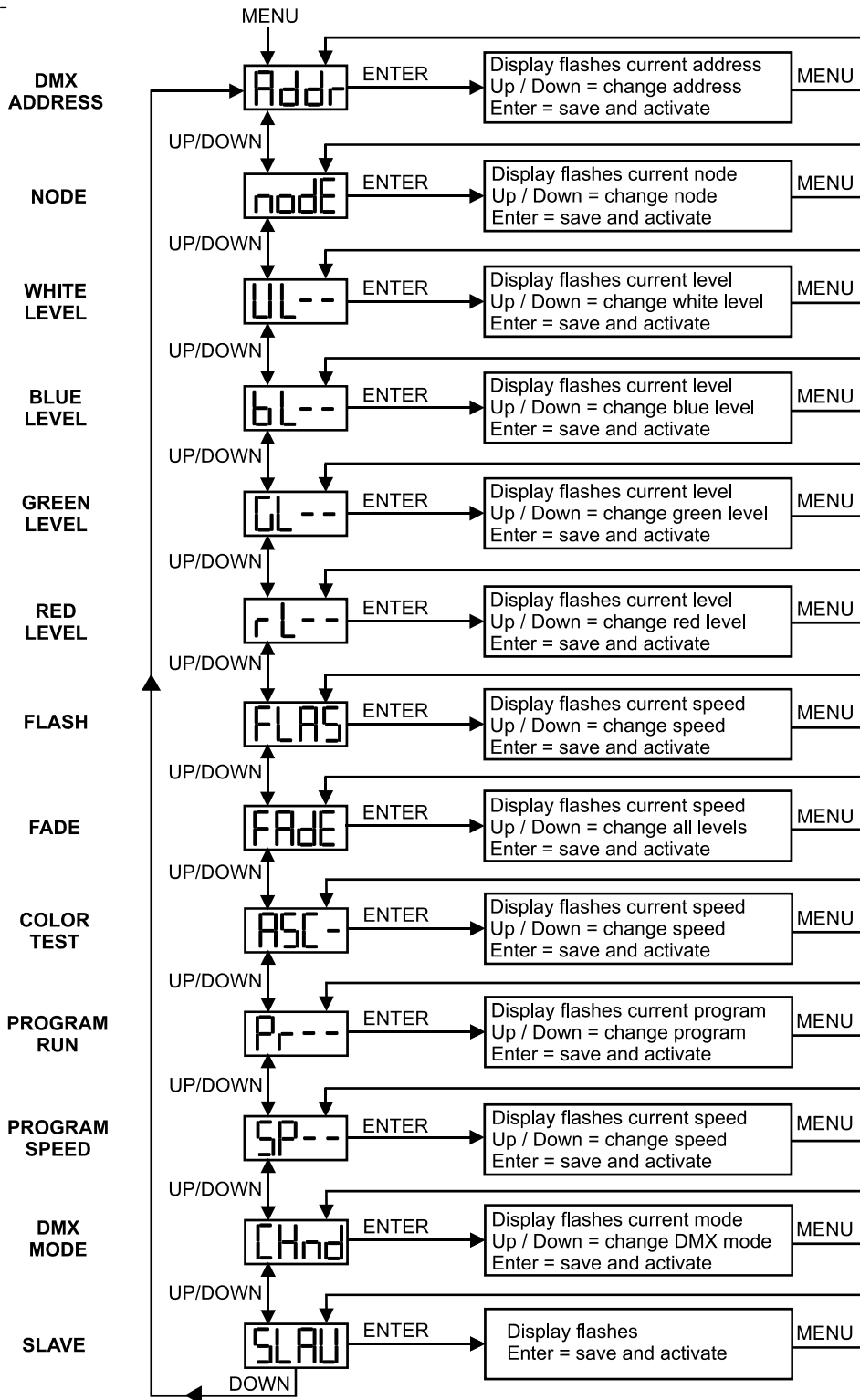

## DMX VALUES AND FUNCTIONS

**3 CHANNEL CONFIGURATION**

DMX CHANNEL	DMX VALUE	FUNCTION
1	0 - 255	Color Mixing (adjusts hue)
2	0 - 255	White Mixing (adjusts color saturation)
3	0 - 255	Master Intensity

**4 CHANNEL CONFIGURATION**

DMX CHANNEL	DMX VALUE	FUNCTION
1	0 - 255	Red Intensity
2	0 - 255	Green Intensity
3	0 - 255	Blue Intensity
4	0 - 255	White Intensity

**5 CHANNEL CONFIGURATION**

DMX CHANNEL	DMX VALUE	FUNCTION
1	0 - 255	Master Intensity
2	0 - 255	Red Intensity
3	0 - 255	Green Intensity
4	0 - 255	Blue Intensity
5	0 - 255	White Intensity

**8 CHANNEL CONFIGURATION**

DMX CHANNEL	DMX VALUE	FUNCTION
1	0 - 255	Master Dimmer
2	0 - 255	Red Level
3	0 - 255	Green Level
4	0 - 255	Blue Level
5	0 - 255	White Level
6	0 - 255	Strobes Currently Set Levels of Ch1 - Ch5
7	0 - 127	A Variety of Patterns Using Currently Set Levels of Ch1 - Ch5
	128 - 255	A Variety of Color Patterns
8	0 - 255	Speed Adjust for Channel 7 Functions



This products is warranted for a period of TWO YEARS from the date of purchase against defects in materials and workmanship.

---

This warranty is subject to the following restrictions and conditions:

- A) If service is required, you may be asked to provide proof of purchase from an authorized Lightronics dealer.
- B) This warranty is valid only for the original purchaser of the unit.
- C) This warranty does not apply to damage resulting from abuse, misuse, accidents, shipping, and repairs or modifications by anyone other than an authorized Lightronics service representative.
- D) This warranty is void if the serial number is removed, altered or defaced.
- E) This warranty does not cover loss or damage, direct or indirect arising from the use or inability to use this product.
- F) Lightronics reserves the right to make any changes, modifications, or updates as deemed appropriate by Lightronics to products returned for service. Such changes may be made without prior notification to the user and without incurring any responsibility or liability for modifications or changes to equipment previously supplied. Lightronics is not responsible for supplying new equipment in accordance with any earlier specifications.
- G) This warranty is the only warranty either expressed, implied, or statutory, upon which the equipment is purchased. No representatives, dealers or any of their agents are authorized to make any warranties, guarantees, or representations other than expressly stated herein.
- H) This warranty does not cover the cost of shipping products to or from Lightronics for service.
- I) Lightronics Inc. reserves the right to make changes as deemed necessary to this warranty without prior notification.