

DESCRIPTION

The AI-1001 is a digital control interface for use with the Lightronics Architectural Series of products. This unit enables dimmer scene activation from multiple remote locations using a handheld IR remote. A LED indicator in the unit provides operator visual feedback when a signal is being received. A dedicated hand held IR Remote transmitter is supplied with the unit.

INSTALLATION

The AI-1001 fits a standard single gang wall switch box. The unit communicates with the AR-1202 dimmer via a 4 wire bus which handles multiple remote units of several types. All wiring associated with the AI-1001 is low voltage.

The AI-1001 connects to the AR-1202 via a shielded 4 conductor cable arranged as 2 twisted pairs. One pair connects the REM DATA - and REM DATA + signals. The other pair carries common (REM COMMON) and power (REM VOLTAGE+). Use the diagram below to make connections between the AI-1001 and the AR-1202 Smart Remote Bus.

Single unit: Connect the 4 cable wires to the screw down terminals on the back of the unit. Connect the cable shield to the REM COMMON pin. The other end of the cable connects to a small terminal strip inside the AR-1202 dimmer. See the AR-1202 Owners Manual for additional wiring details.

Multiple Units: Multiple AI-1001 units may be utilized on the same bus. Follow the instructions for a single unit for the first AI-1001. Connect pin 1 of the second unit to pin 1 of the first unit and continue for the remaining wires. Repeat the procedure for additional AI-1001 units.

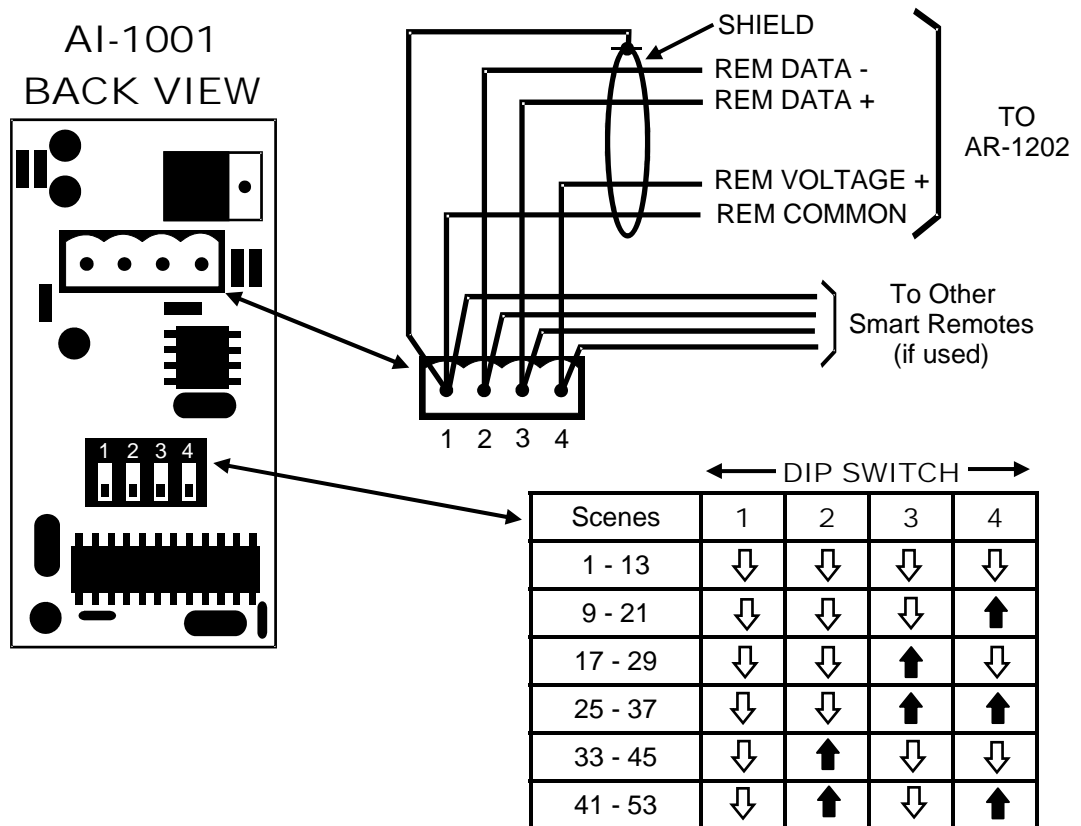

HAND REMOTE

The hand held remote unit is a infra red transmitter which uses 2 AA batteries. It weighs 3 ounces (including batteries). The overall outside dimensions are 5.75"L X 1.5"W x .75"D.

OPERATION

No setup or turn on procedure is needed for the AI-1001. The AR-1202 dimmer provides the power. The AI-1001 automatically senses and encodes IR signals from the hand held remote to activate scenes stored in the AR-1202 dimmer.

The IR hand remote can turn on 13 different scenes in an exclusive manner (1 scene active at a time). The OFF button will shut off any/all scenes. Scenes to be activated by the AI-1001 must have already been created and stored in the AR-1202. See the AR-1202 Owners Manual for instruction on programming scenes.

The AI-1001 may be set, by using the DIP switches on the back of the unit, to access different groups or blocks of 13 scenes each. The table on the preceeding page shows the switch settings and their associated scene number range.

MAINTENANCE AND REPAIR

TROUBLESHOOTING

Ensure that the 2 AA batterys in the hand remote are not discharged.

Check the cable and its connections

If the unit is being used with an AR-1202 system - ensure that one (and only one) of the AR-1202 dimmer(s) in the system is set to UNIT ADDRESS 00.

Make sure that the DIP switches on the back of the AI-1001 are set to the desired scene block.

OWNER MAINTENANCE

There are no user serviceable parts in the unit. Service by other than Lightronics authorized agents will void your warranty.

OPERATING AND MAINTENANCE ASSISTANCE

Dealer and Lightronics Factory personnel can help you with operation or maintenance problems. Please read the applicable parts of this manual before calling for assistance.

If service is required - contact the dealer from whom you purchased the unit or contact Lightronics, Service Dept., 509 Central Drive, Virginia Beach, VA 23454 TEL: (757) 486-3588.



All Lightronics products are warranted for a period of TWO/FIVE YEARS from the date of purchase against defects in materials and workmanship.

This warranty is subject to the following restrictions and conditions:

- A) If service is required, you may be asked to provide proof of purchase from an authorized Lightronics dealer.
- B) The FIVE YEAR WARRANTY is only valid if the warranty card is returned to Lightronics accompanied with a copy of the original receipt of purchase within 30 DAYS of the purchase date, if not then the TWO YEAR WARRANTY applies. Warranty is valid only for the original purchaser of the unit.
- C) This warranty does not apply to damage resulting from abuse, misuse, accidents, shipping, and repairs or modifications by anyone other than an authorized Lightronics service representative.
- D) This warranty is void if the serial number is removed, altered or defaced.
- E) This warranty does not cover loss or damage, direct or indirect arising from the use or inability to use this product.
- F) Lightronics reserves the right to make any changes, modifications, or updates as deemed appropriate by Lightronics to products returned for service. Such changes may be made without prior notification to the user and without incurring any responsibility or liability for modifications or changes to equipment previously supplied. Lightronics is not responsible for supplying new equipment in accordance with any earlier specifications.
- G) This warranty is the only warranty either expressed, implied, or statutory, upon which the equipment is purchased. No representatives, dealers or any of their agents are authorized to make any warranties, guarantees, or representations other than expressly stated herein.
- H) This warranty does not cover the cost of shipping products to or from Lightronics for service.
- I) Lightronics Inc. reserves the right to make changes as deemed necessary to this warranty without prior notification.

