



OWNERS MANUAL

Revision 1.87
02/07/2005

TABLE OF CONTENTS

AR-1202 UNIT DESCRIPTION	3
EXTERNAL CONTROLS	3
POWER REQUIREMENTS	3
INSTALLATION	3
Physical Location	3
Power Input Connections	3
Three Phase Power Connections	4
Single Phase Power Connections	5
External Connections	6
Lighting Load Connections	6
Control Signal Connections	6
DMX Console Connections	7
DMX Termination	7
Smart Remote Connections	8
Simple Remotes Connections	9
AR-1202 Unit Setup	9
Using The Menu System	10
Input Power Setup	10
Unit Address Assignment	10
Dimmer Channel Assignment	11
Relay Mode Assignment	11
Console Lockout	11
Creating And Editing Scenes	11
Scene Fade Time	11
Scene Blackout Fade Time	12
OPERATION	12
Manual Operation	12
DMX Console Operation	12
Smart Remotes Operation	12
Button And IR Smart Remotes Operation	12
Fader Smart Remotes Operation	13
Simple Remotes Operation	13
MAINTENANCE AND REPAIR	13
Owner Maintenance	13
Internal Fuse	13
Operating And Maintenance Assistance	13
AR-1202 UNIT SPECIFICATIONS	14
CONTROL CIRCUIT BOARD CONNECTIONS	15
DIMENSIONS AND MOUNTING	16
WARRANTY	17

AR-1202 UNIT DESCRIPTION

The AR-1202 consists of a processor and 12 dimmer channels of 2.4KW each. Each dimmer channel is protected by a 20 Amp circuit breaker. Heavy duty filtering chokes are used to reduce noise. Dimmer channel semiconductors exceed a 200% load carrying capacity overhead allowance. All components and sub systems are UL recognized components. All internal wiring conforms to UL standards as they apply to industrial controls. Dimensions and weight information is given at the end of this manual.

EXTERNAL CONTROLS

The AR-1202 can communicate with remotely located control equipment in several ways.

A USITT DMX-512 protocol bus is provided so the unit may be used with any DMX lighting console. The AR-1202 is fully patchable with respect to the DMX bus.

The AR-1202 may also be controlled by several types of wall mounted smart remote stations. Smart remotes communicate with the AR-1202 by way of a low voltage RS-485 bus. This bus is completely separate from the DMX bus. Smart remotes are used to activate scenes which have been prestored in the AR-1202. There are several types of smart remote stations. Multiple smart remotes of the same or different types may be chained together on the RS-485 bus. The same RS-485 bus may be chained to multiple AR-1202 dimmer packs.

The AR-1202 may additionally be controlled by an arrangement of one or more momentary switches (simple remotes). The switches may be used to control a specific set of scenes prestored in the AR-1202.

POWER REQUIREMENTS

The AR-1202 may be operated from 50/60 Hz, 120/208 VAC, three phase power or from 50/60 Hz, 120/240 VAC, single phase power. Input power to the unit must be capable of delivering 80 Amps per line if using three phase or 120 Amps per line if using single phase power.

The AR-1202 is intended to be used with power feeds in a WYE configuration. A NEUTRAL line is required.

The AR-1202 will not operate correctly using only 2 phases of a 3 phase power service. This holds true regardless of whether the unit is set up for single or three phase power.



INSTALLATION

PHYSICAL LOCATION

The unit is intended for **INDOOR OPERATION ONLY** and should not be subjected to excessive moisture or heat. The unit should be installed where a supply of circulating air is available. The AR-1202 is designed to be wall mounted in a equipment room or electrical distribution area. The ambient air in the installation area should be below 86 deg F.

The AR-1202 is convection cooled by heatsinks on the left and right sides of the unit. Provide spacing between the unit and other equipment to allow air flow around the unit (particularly around the finned heat sinks). See “Dimensions and Locations” in this manual for more information concerning mounting of the unit.

POWER INPUT CONNECTIONS

 **WARNING** 
MAKE CERTAIN POWER IS REMOVED
FROM THE FEED CIRCUITS
BEFORE YOU BEGIN INSTALLATION.

Consult applicable electrical codes to determine the proper wire type and methods.

The AR-1202 operates using either three phase 120/208 VAC or single phase 120/240 VAC power. The unit is shipped from the factory as a **THREE PHASE** unit. It can be field converted to single phase unit.

THREE PHASE POWER CONNECTIONS



WARNING



MAKE CERTAIN POWER IS REMOVED FROM THE FEED CIRCUITS BEFORE YOU BEGIN INSTALLATION.

REQUIREMENTS

True 120/208VAC three phase power must be supplied to operate the AR-1202 in the 3 phase configuration. This means that the voltage across any two lines must be 208 VAC. The feed circuit must be able to supply 80 Amps for each hot line.

The feed circuit must be able to supply 120 Amps for each line.

THE AR-1202 WILL NOT OPERATE IN A THREE PHASE CONFIGURATION FROM 2 LINES OF EITHER A SINGLE OR 3 PHASE SUPPLY CIRCUIT.

CONNECTIONS

Connect the 3 in hot feed lines to the 3 terminals on the input power terminal block (H1, H2, H3). When operating on three phase power, the unit expects a particular phase sequence for these 3 input power connections. NO damage will occur if the order is reversed but dimming will not occur correctly and some channels will appear to be in a on/off mode. This condition can be corrected at the AR-1202 front panel without rewiring anything. See the section POWER SETUP for specific information.

Connect the feed neutral to the NEUTRAL bus bar.



Connect the feed ground to the GROUND lug.

HIGH VOLTAGE CIRCUITRY IS EXPOSED WHEN THE CABINET DOOR IS OPEN. DO NOT ALLOW THE UNIT TO OPERATE OR HAVE POWER APPLIED TO IT WHILE THE DOOR IS OPEN.

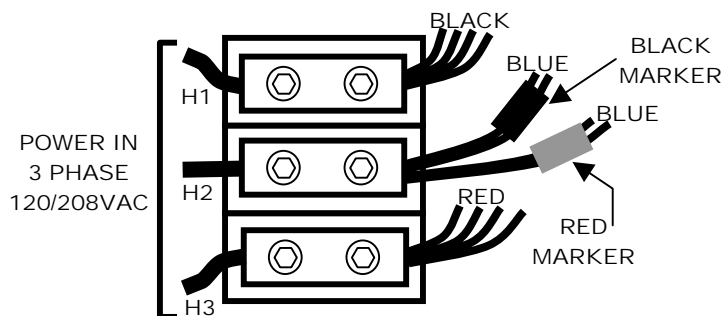
THREE PHASE POWER CONNECTIONS



SINGLE PHASE POWER CONNECTIONS

 **WARNING** 
MAKE CERTAIN POWER IS REMOVED
FROM THE FEED CIRCUITS
BEFORE YOU BEGIN INSTALLATION.

REQUIREMENTS

Actual 120/240VAC single phase power must be supplied to operate the AR-1202 in the single phase configuration. The unit should be connected to two hot lines which are NOT the same phase. The 2 hot lines must be actual single phase power. This means that the voltage across the two lines must be 240 VAC.

The feed circuit must be able to supply 120 Amps for each line.

THE AR-1202 WILL NOT OPERATE AS A SINGLE PHASE UNIT USING 2 LINES OF A 3 PHASE SUPPLY CIRCUIT.

CONNECTIONS

There are three terminals on the input power terminal block (H1, H2, H3). When operating the AR-1202 on single phase power, the center (H2) terminal is not used.

The wires connected to the left side of the H2 terminal contain color coded sleeves (RED and BLUE). These wires must be moved and distributed to the H1 and H3 terminals. Remove the wires from the H2 terminal and connect them to H1 and H3 such that the sleeve color matches the wire colors on H1 and H3.

Connect the feed neutral to the NEUTRAL bus bar.

Connect the feed ground to the GROUND lug.

HIGH VOLTAGE CIRCUITRY IS EXPOSED WHEN THE CABINET DOOR IS OPEN. DO NOT ALLOW THE UNIT TO OPERATE OR HAVE POWER APPLIED TO IT WHILE THE DOOR IS OPEN.

SINGLE PHASE POWER CONNECTIONS

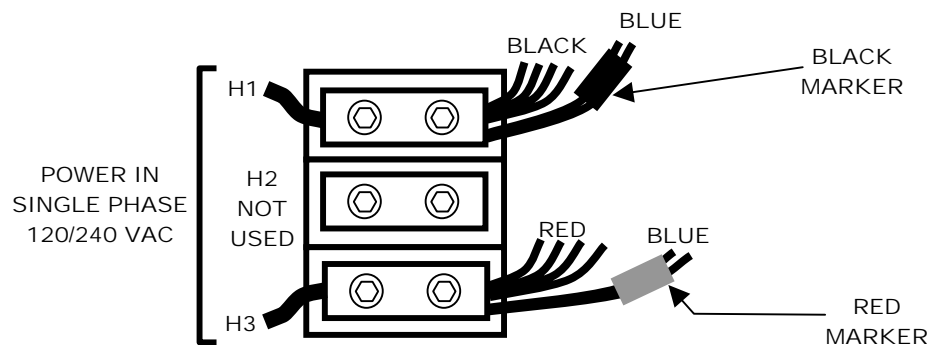

EXTERNAL CONNECTIONS

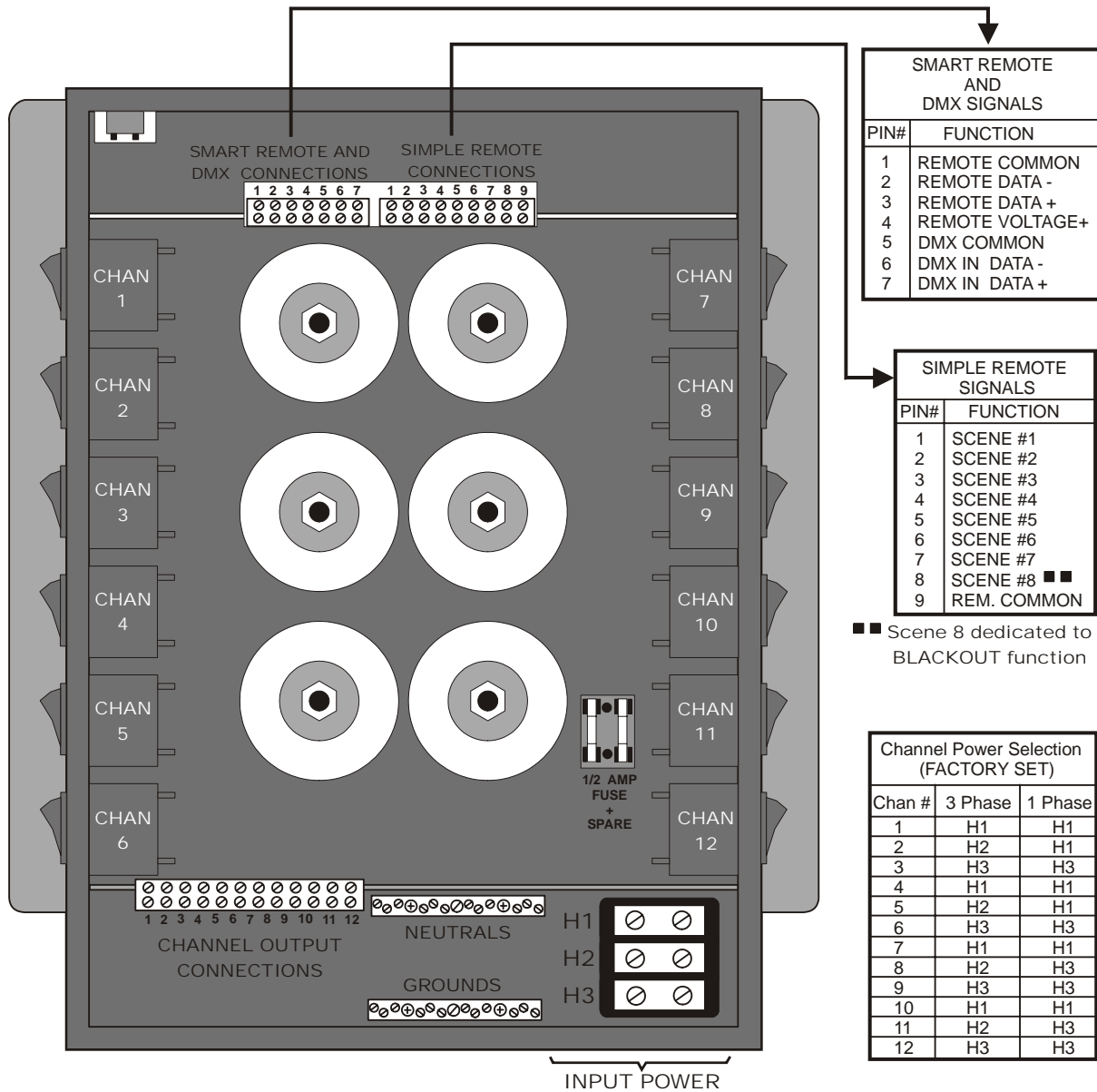

LIGHTING LOAD CONNECTIONS

Lighting to be controlled by the AR-1202 must be connected to the terminal strip located on the front of the lower separator panel of the cabinet. The lowest number dimmer channel output connection is on the left. See the EXTERNAL CONNECTIONS DIAGRAM. Above. The load connections terminal strip is shown as CHANNEL OUTPUT CONNECTIONS in the diagram.

CONTROL SIGNAL CONNECTIONS

Terminal strips are provided for connection to DMX consoles, smart remotes, and simple remote stations. Specific wiring connection point information for all external control signals is shown in the EXTERNAL CONNECTIONS diagram above.

DMX CONSOLE CONNECTIONS

DMX console signals to the AR-1202 should be transmitted over a twisted pair, shielded, low capacitance cable. A DMX console transmits from a female, 5 Pin XLR Connector.

See the diagram "EXTERNAL CONNECTIONS" and the example below for specific connection information.

DMX TERMINATION

A DMX bus should be terminated (only) at the last receiving device on the chain. This is done by connecting a 120 ohm, 1/4 watt resistor across the DMX DATA - and DMX DATA + lines.

A DMX bus should be daisy chained to all its receiving units. It should NOT be connected in a star arrangement with multiple "home runs".

CAUTION
 REMOVE ALL POWER FROM THE AR-1202
 BEFORE MAKING OR CHANGING DMX
 CONSOLE CONNECTIONS.

DMX CABLE CONDUCTOR ARRANGEMENT FOR TWISTED PAIR, SHIELDED CABLE

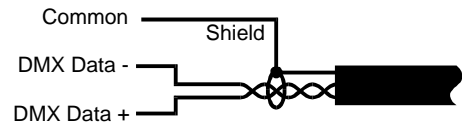

CONSOLE DMX OUTPUT CONNECTOR (5 PIN FEMALE XLR)

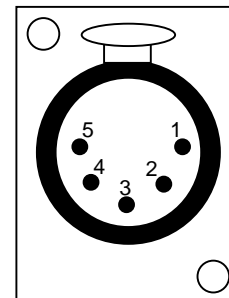

DMX CONNECTIONS EXAMPLE

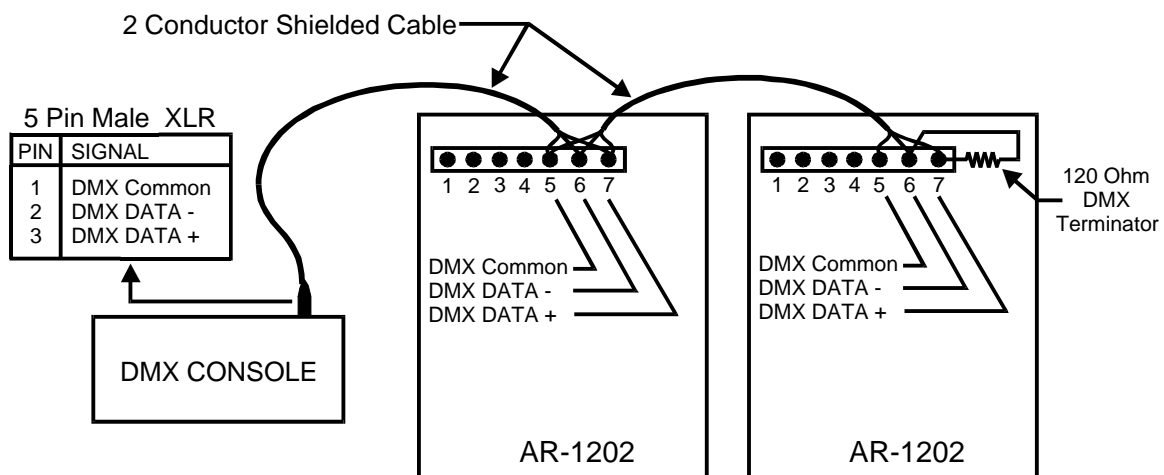

SMART REMOTE CONNECTIONS

There are two types of smart remotes (push button and fader) which can be used with the AR-1202. There are multiple models of each type. They all connect to a common RS-485 bus which is controlled by a AR-1202. Additional AR-1202 dimmers may also be connected on the same bus. One of them will be set as a master bus controller by the UNIT ADDRESS ASSIGNMENT. Smart remote signals to the AR-1202 are transmitted over a two twisted pair, shielded, low capacitance cable. One pair carries the RS-485 signal and the other provides a low voltage power and common to the remotes.

A smart remote bus should be daisy chained to all its receiving units. It should NOT be connected in a star arrangement with multiple "home runs".

Each smart remote has a 4 pin connector with screw down terminals to connect to the RS-485 bus. You must get the exact wiring pinout information for the remote unit from its owners manual.

CAUTION
REMOVE ALL POWER FROM THE AR-1202 BEFORE MAKING OR CHANGING SMART REMOTE CONNECTIONS.

See the diagram "EXTERNAL CONNECTIONS" and the example below for specific connection information.

SMART REMOTES CABLE CONDUCTOR ARRANGEMENT FOR DUAL TWISTED PAIR, SHIELDED CABLE

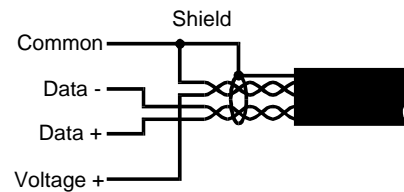

SMART REMOTE CONNECTIONS EXAMPLE

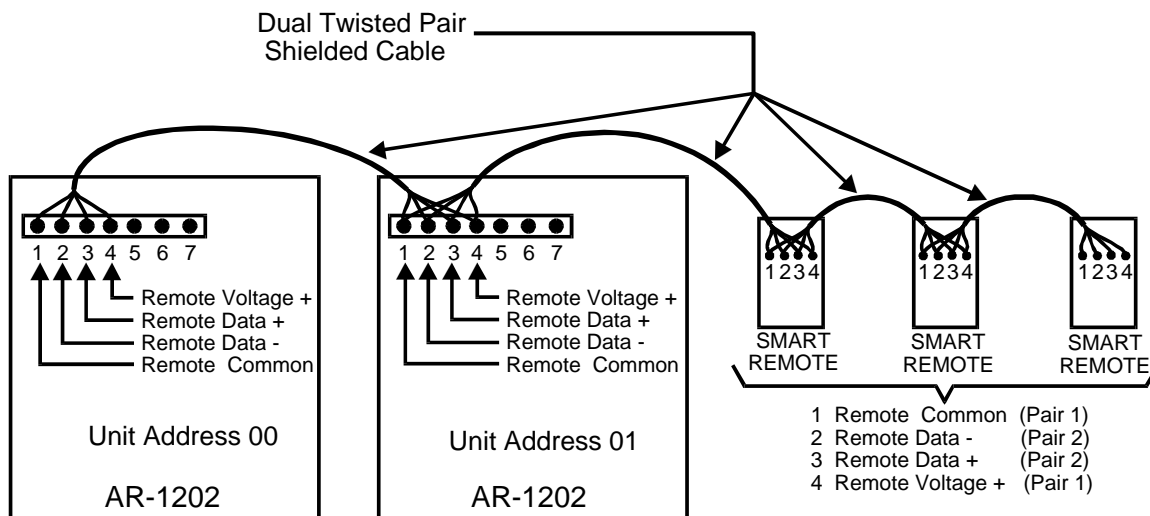

SIMPLE REMOTE CONNECTIONS

CAUTION
REMOVE ALL POWER FROM THE AR-1202
BEFORE MAKING OR CHANGING SIMPLE
REMOTE CONNECTIONS.

Scenes 1 - 7 (stored in the AR-1202) may be accessed by simple remotes. A BLACKOUT FUNCTION may also be accessed. A simple remote is any switch which can provide a momentary contact closure that can be applied to a specific pin on the AR-1202 SIMPLE REMOTE CONNECTIONS terminal strip.

The SIMPLE REMOTE COMMON is routed to the remote. When the remote is operated the closure brings the signal back to the applicable simple remote scene number connection point at the AR-1202 terminal strip. almost any available low voltage wire may be used since these connections are contact closures.

Multiple simple remotes may be used. Additionally multiple AR-1202 units may be chained to one or more simple remotes

See the diagram "EXTERNAL CONNECTIONS" and the example below for specific connection information.

SIMPLE REMOTE CONNECTIONS EXAMPLE USING A LIGHTRONICS APP01

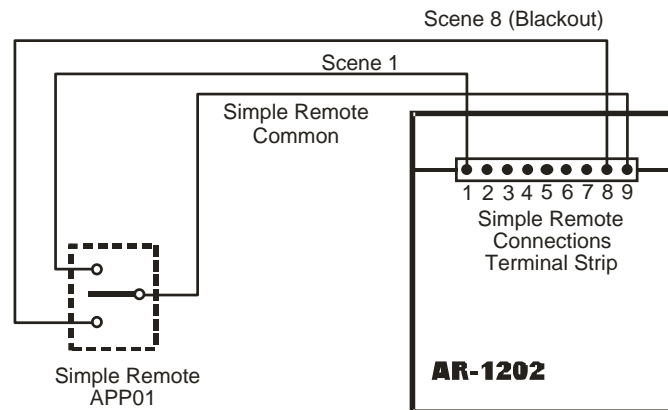

AR - 1202 UNIT SETUP

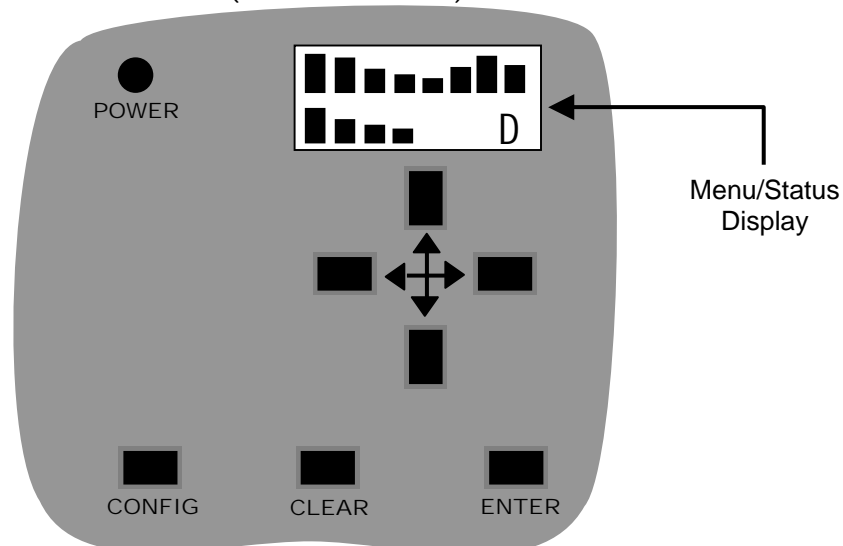
FRONT PANEL
(PARTIAL VIEW)

The AR-1202 must be set up (configured) as part of the installation process in any application. This set up process is done from the front panel of the unit. Unit setup should be done in the following order.

The Power Setup must be done first.

The unit address must be correctly set if smart remote wall stations will be used .

The units output channels should be assigned (or patched) to the desired console control channels if a DMX console will be used.

The last setup step creates prestored scenes to be activated from the remote control stations.

USING THE MENU SYSTEM

The **CONFIG** button steps through the display menus. There are currently four menus available. They are: “SCENE SETUP”, “DIMMER SETUP”, “SET UNIT ADDRESS”, and “POWER SETUP”. When one of these messages is displayed you can push the **ENTER** button to access that function. The **CLEAR** button will return the unit to its normal operating mode and cause the MENU/STATUS display to show the channel level bar graph. The **CLEAR** button DOES NOT clear entered values. The arrow buttons are used to set values for various menu selections.

INPUT POWER SETUP

CAUTION
TURN OFF ALL CHANNELS AND OPEN ALL
CHANNEL CIRCUIT BREAKERS BEFORE
CHANGING THE INPUT POWER SETUP.

In addition to making the correct power connections for the power source at your installation the AR-1202 must be set up to correctly respond to the power type.

At the AR-1202 front panel - push **CONFIG** until “POWER SET UP” appears on the Menu/Status display.

POWER
SETUP

Push **ENTER**. The display shows the current power setup. For example:

POWER I n
60Hz 1PN

Use the \uparrow and \downarrow buttons to select the configuration corresponding to the power supplied to the AR-1202. The available choices are shown below.

60Hz 1PN	60Hz 1 Phase, Normal Phase Rotation
60Hz 3PN	60Hz 3 Phase, Normal Phase Rotation
60Hz 3PR	60Hz 3 Phase, Reverse Phase Rotation
50Hz 1PN	50Hz 1 Phase, Normal Phase Rotation
50Hz 3PN	50Hz 3 Phase, Normal Phase Rotation
50Hz 3PR	50Hz 3 Phase, Reverse Phase Rotation

You may not know in advance if you should use the Normal or Reverse rotation choice for 3 phase power. If this is the case then use Normal Phase Rotation.

NO damage will occur if the rotation is actually reverse but dimming will not occur correctly and some channels will appear to be in a on/off mode. This will be readily apparent when the unit is operated. You can then change the setting.

UNIT ADDRESS ASSIGNMENT

At the AR-1202 front panel - push **CONFIG** until “SET UNIT ADDRESS” appears on the Menu/Status display.

SET UNIT
ADDRESS

Push **ENTER**. The display shows the unit address.

SET UNIT
I D \updownarrow 00

Set the desired address by pushing the \uparrow and \downarrow buttons.

Push **ENTER**. Then push **CLEAR** to return to the normal operating mode.

NOTE: When using a single AR-1202 unit system, the unit address **MUST BE SET TO 00**. One of the units in a multiple unit system must be set to address 00. Other units should be assigned in a consecutive order.

NOTE: When using a single AR-1202 unit system, the unit address **MUST BE SET TO 00**. One of the units in a multiple unit system must be set to address 00. Other units should be assigned in a consecutive order.

DIMMER CHANNEL ASSIGNMENT

Dimmer channel assignment is used to assign or patch individual AR-1202 channels (circuits) to a DMX control channel. Each dimmer channel (1 - 12) is fully patchable to any of 512 DMX control channels.

At the AR-1202 front panel - push **CONFIG** until “DIMMER SETUP” appears on the Menu/Status display.



Push **ENTER**. The display shows the dimmer output on the top line prefixed by “OUT” and a “D” or “R” which indicates that the channel is in the either relay or dimming mode. The currently assigned console channel is shown on the lower line prefixed by “DMX”.

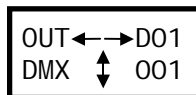

Set each dimmer channel to the desired DMX channel using the → ← ↓ ↑ buttons. Push **ENTER** after each channel assignment. Push **CLEAR** to return the AR-1202 to its normal operating mode. It will not clear your settings.

RELAY MODE ASSIGNMENT: Pushing **CONFIG** while assigning a channel will switch the channel between dimming and relay operation. The upper right corner of the display will be prefixed with “D” or “R” accordingly. Remember to push **ENTER** after each change.

CONSOLE LOCKOUT: You can set any dimmer channel output to ignore DMX signal inputs from a control console by assigning it to DMX channel 0. This feature can be used with “house lights” or other special lighting. The channel will still respond to the wall remote stations but the DMX console is “locked out”.

CREATING AND EDITING SCENES

At the AR-1202 front panel - push **CONFIG** until “SCENE SETUP” appears on the Menu/Status display.



Push **ENTER**. The display shows the current scene number.

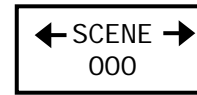

Use the ← and → buttons to select the scene you want to set up. Scene 00 controls blackout fade time. Scene 01 is the first actual scene.

Push **ENTER**. The display shows the scene setup menu.

The current channel number is shown on the display upper left. The current scene number (which was selected in the previous step) is shown on the display

upper right. The settings for three channels are shown on the lower display row. The LEFT channel is the current channel (the channel which you will set the output level for).

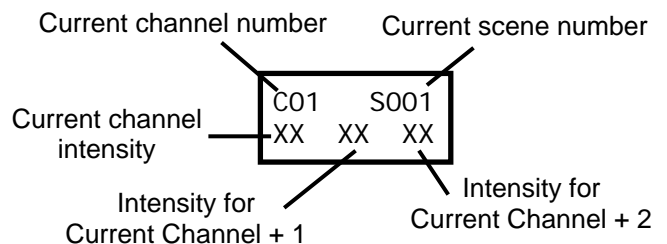

Use the ↓ and ↑ buttons to set the channel output intensity. The display shows the intensity setting as a number between 0% and 100%. A 100% setting is indicated by “FL”. A “XX” setting means that the channel will be ignored for the current scene.

Push **ENTER** after the channel level is set.

Use the ← and → buttons to proceed to the next channel to be set up. The lower row of the display will shift to the left. Repeat the channel intensity selection for that channel.

Push **CLEAR** when all the channels for the selected scene are set. This will not clear you scene settings.

To setup another scene - repeat the process above using a different scene selection.

SCENE FADE TIME

A fade time may be set individually for each scene. This is the time elapsed between a scene fully active and the

next scene fully active. The factory default fade time is 3 seconds. Fade time may be set between .5 and 99.5 seconds and is set from the **SCENE SETUP** menu (normally as you set channel intensities for the scene).

- 1 To access the **SCENE SETUP** Menu - push the **CONFIG** button once. Then push **ENTER**.
- 2 Use the ↓ and ↑ buttons to select the desired scene. Then push the **ENTER** button. The display will show the current settings for the scene.
- 3 Use the → and ← buttons to proceed **BEYOND** the last channel (channel 16) for the scene. The display will indicate the current fade time for the scene.
- 4 Use the ↓ and ↑ buttons to set the desired fade time. Then push the **ENTER** button.
- 5 Push The **CLEAR** button to return the AR-1202 to its normal status display.

SCENE BLACKOUT FADE TIME

Fade time for the remote stations blackout function is set as an independent function. The procedure is similar to that for other scenes except the **BLACKOUT** function is accessed by selecting **SCENE 0** from the **SCENE SETUP** menu. Factory default fade time is 3 seconds. Blackout fade time may be set between .5 and 99.5 seconds. Use the ↓ and ↑ buttons to set the fade time. Push **ENTER** after the fade time is set.

OPERATION

MANUAL OPERATION

Individual dimmer channels may be operated from the AR-1202 front panel. This is useful during testing and setup operations. Use the → and ← buttons to select a channel. The associated channel on the bar graph display will flash. Use the ↓ and ↑ buttons to set the lighting intensity for the selected channel.

Manual operation combines with DMX and remote stations settings but does not lock them out.

The **CLEAR** button will turn off all channels when operating manually.

DMX CONSOLE OPERATION

If a DMX signal is present when the AR-1202 is turned on it will automatically respond to it. A "D" will be shown in the lower right corner of the LCD display if a valid DMX signal is present. Channel intensity levels will be shown on the bar graph display.

Channel Intensity Bar Graph

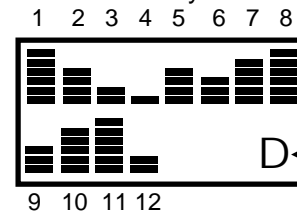

Valid DMX Indication

SMART REMOTES OPERATION

The AR-1202 can store 64 scenes which may be activated by smart remotes. See the section "Creating and Editing Scenes" for info about programming the scenes. These scenes are grouped according to which type of smart remote can access them. Scenes 1 - 48 are reserved for push button and IR remotes. Scenes 51 - 64 are used with fader remotes. If multiple AR-1202 units are connected to a smart remote then each AR-1202 will activate its own corresponding scene.

Both push button and fader remotes may be connected on the same smart remote bus.

BUTTON AND IR SMART REMOTES OPERATION

These remotes activate individual scenes within a block of scenes which have been stored in the AR-1202 on an "exclusive" basis. In other words only one scene may be on at a time. Currently available remotes are the AC-1009, AC-2016 and AI-1001.

You can select which block of scenes will be activated by the remote. This is done by DIP switches on the back of the remote. For instance, an AC-1009 can be set to control scenes 1 - 8, scenes 9-16 or other blocks of 8

consecutive scenes. Refer to the smart remote owner manual for specific info on setting scene addressing. Multiple smart remotes may be but are not required to be set to the same block of scenes.

FADER SMART REMOTES OPERATION

These remotes specific individual scenes which have been stored in the AR-1202 on a "pile on" basis. In other words multiple scenes will merge together in a "greatest of " fashion. This means that the intensity of any given channel will go to the highest level of all the scenes which use it. Currently available fader remotes are the AF-2004, AF-3007 and AF-5013.

You CANNOT select which block of scenes will be activated by the remote. Fader smart remotes are NOT scene block addressable. These remotes always use scene 51 for the lowest numbered fader on the remote. The remaining faders will use the next consecutively numbered scenes (52, 53, 54, etc). If multiple fader remotes are connected to one or more AR-1202's then they will all activate scenes beginning at scene 51 in each AR-1202.

SIMPLE REMOTES OPERATION

Scenes 1 - 7 (stored in the AR-1202) may be accessed by simple remotes. A BLACKOUT FUNCTION may also be accessed. A simple remote is any switch which can provide a momentary contact closure that can be applied to a specific pin on the AR-1202 SIMPLE REMOTE UNIT INPUTS terminal strip. Lightronics currently offers a APP01 simple remote. This is a "center off , single pole, double throw, momentary toggle switch". It can be used as a simple entrance switch to activate a scene when someone enters an area.

Alternative devices such as relays, timers, and motion sensors can be connected to AR-1202 dimmers as simple remotes. These are available from a variety of manufacturers.

Operation of a simple remote is dependent upon the device used. In the case of the Lightronics APP01 it is a simple matter of pushing the switch.

MAINTENANCE AND REPAIR

OWNER MAINTENANCE

There are no user serviceable parts inside the unit.

INTERNAL FUSE

WARNING



MAKE CERTAIN POWER IS REMOVED
FROM THE FEED CIRCUITS
BEFORE HANDLING THE UNIT.



The AR-1202 has a 1/2 amp, 250V, Type ABC, fast acting fuses on the inside the cabinet. It provides protection only for the internal electronic control circuitry. It may be replaced ONLY by a fuse of identical type and size.

Contact a qualified electrical maintenance person if you suspect this fuse has blown.

HIGH VOLTAGE CIRCUITRY IS EXPOSED WHEN THE CABINET DOOR IS OPEN. DO NOT ALLOW THE UNIT TO OPERATE OR HAVE POWER APPLIED TO IT WHILE THE DOOR IS OPEN.

The best way to prolong the life of your unit is to keep is cool, clean, and dry. It is important that the cooling intake and exit vent holes are clean and unobstructed.

Service by other than Lightronics authorized agents may void your warranty.

OPERATING AND MAINTENANCE ASSISTANCE

If service is required, contact the dealer from whom you purchased the equipment or contact:

Lightronics, Service Department
509 Central Drive
Virginia Beach, VA 23454
TEL 757 486 3588.

Lightronics recommends that you record the serial number of your unit for future reference.

SERIAL NUMBER _____

CONTROL CIRCUIT BOARD CONNECTIONS

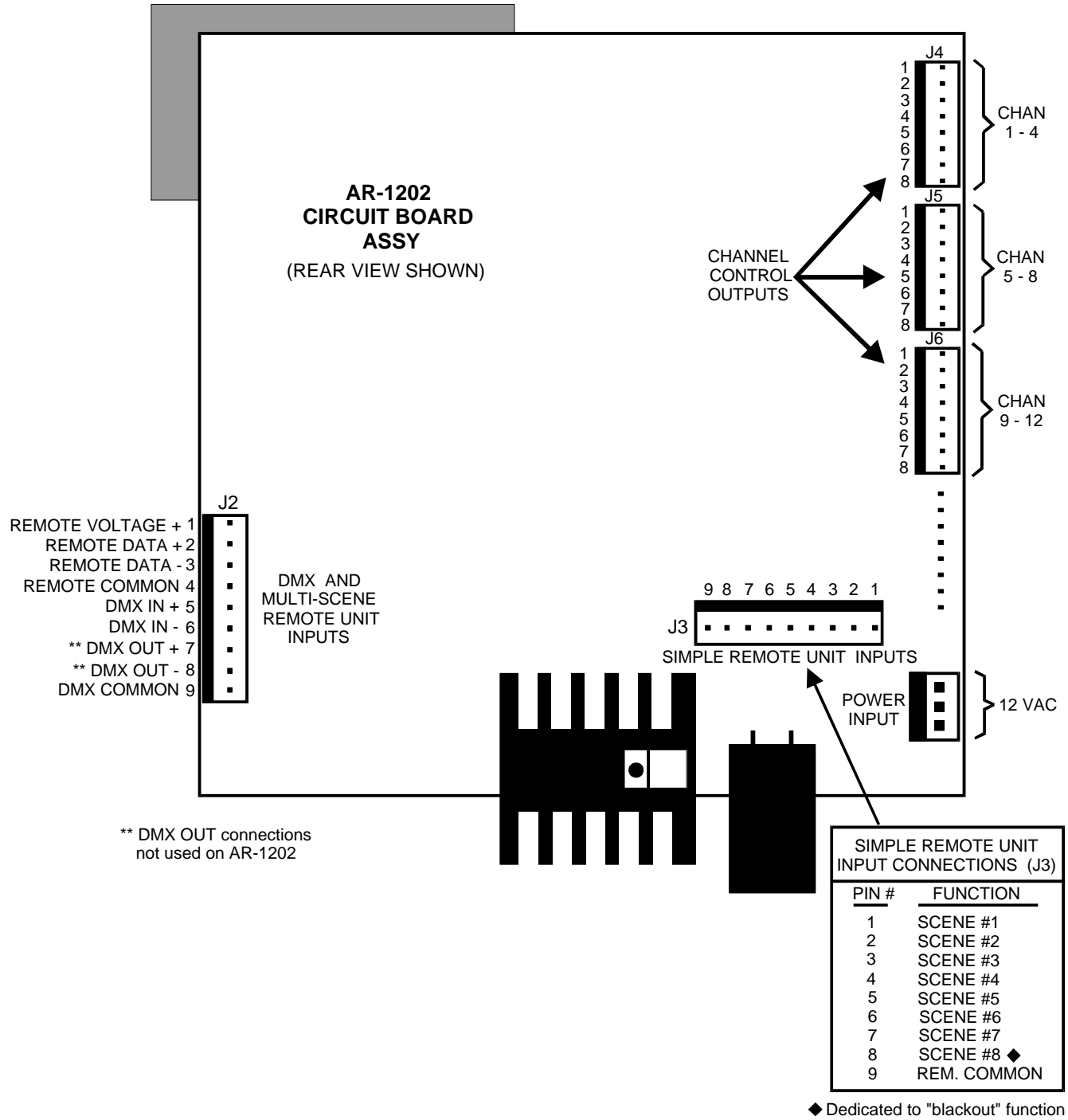

DIMENSIONS AND MOUNTING

Cabinet Front View With Door Removed

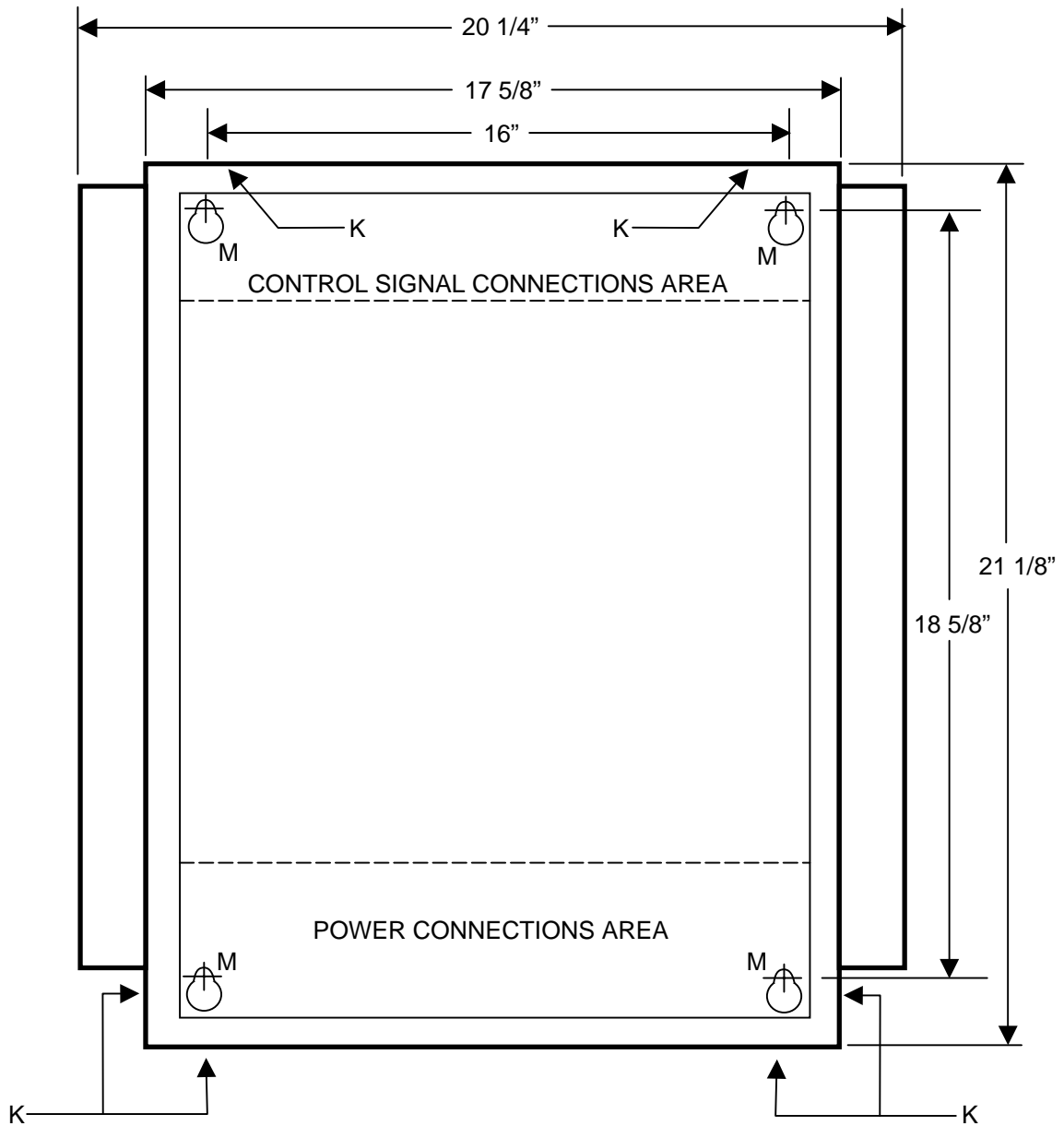

NOTES:

Dimensions are +/- 1/16". This drawing is not to scale.

Cabinet Clearance Depth is 6 1/4"

Mounting holes indicated by "M" will accommodate 1/4" bolt.

Double 1/2, 3/4 inch knockout holes provided at locations indicated by "K".

Suggested Mounting Procedure:

Drill top holes level, 16" apart at desired height.

Partially install bolts (enough to hold cabinet weight).

Hang cabinet from top bolts.

Drill lower holes and install lower bolts – tighten all bolts.

AR-1202 UNIT SPECIFICATIONS

CHANNELS/CAPACITY:	12 Channels @ 2400 Watts each channel
POWER REQUIREMENTS:	120/208VAC three phase,80 Amps each line OR 120/240VAC single phase, 120 Amps each line
POWER DEVICES:	Dual 65 Amp SCRs
POWER CONNECTOR:	Terminal strip
CHANNEL OUTPUT:	Terminal Strip
CIRCUIT BREAKERS:	20 Amp fast acting
MINIMUM LOAD:	15 Watts
CURVE:	Modified square law
FILTER RISE TIME:	600 usec. minimum
OUTPUT FUNCTION:	DIMMER or RELAY selectable
CONTROL INPUT:	DMX-512 U.S.I.T.T. standard
FRONT PANEL:	8 char. x 2 line LCD display
REMOTE NETWORK:	RS-485, 62.5 Kbaud, bidirectional 9 bit network
LOCAL PRESETS:	64 scenes standard. Expandable to 255 scenes
CLOSURE INPUT:	8 inputs for single, dual button, or combine stations
REMOTE STATIONS:	Total of 32 remote stations with unique system addresses
SLAVE UNITS:	Up to 31 additional units may be added
SIZE :	21 1/8"H x 20 1/4"W x 6 1/4"D
WEIGHT:	61 lbs (70 lbs shipping weight)



All Lightronics products are warranted for a period of TWO/FIVE YEARS from the date of purchase against defects in materials and workmanship.

This warranty is subject to the following restrictions and conditions:

- A) If service is required, you may be asked to provide proof of purchase from an authorized Lightronics dealer.
- B) The FIVE YEAR WARRANTY is only valid if the warranty card is returned to Lightronics accompanied with a copy of the original receipt of purchase within 30 DAYS of the purchase date, if not then the TWO YEAR WARRANTY applies. Warranty is valid only for the original purchaser of the unit.
- C) This warranty does not apply to damage resulting from abuse, misuse, accidents, shipping, and repairs or modifications by anyone other than an authorized Lightronics service representative.
- D) This warranty is void if the serial number is removed, altered or defaced.
- E) This warranty does not cover loss or damage, direct or indirect arising from the use or inability to use this product.
- F) Lightronics reserves the right to make any changes, modifications, or updates as deemed appropriate by Lightronics to products returned for service. Such changes may be made without prior notification to the user and without incurring any responsibility or liability for modifications or changes to equipment previously supplied. Lightronics is not responsible for supplying new equipment in accordance with any earlier specifications.
- G) This warranty is the only warranty either expressed, implied, or statutory, upon which the equipment is purchased. No representatives, dealers or any of their agents are authorized to make any warranties, guarantees, or representations other than expressly stated herein.
- H) This warranty does not cover the cost of shipping products to or from Lightronics for service.
- I) Lightronics Inc. reserves the right to make changes as deemed necessary to this warranty without prior notification.