



DB - 624

TRUSS MOUNT DIMMER

OWNERS MANUAL

Revision 0.6

09/19/2008

DB - 624 LIGHTBAR DIMMER

Version: 0.6

OWNERS MANUAL

09/19/2008

DESCRIPTION OF UNIT

The DB-624 is a 6 channel dimmer with a capacity of 2,400 watts per channel giving a total of 14,400 watts. The DB-624 is controlled by a control console using the USITT DMX-512 lighting control protocol. Individual channels may be set to operate in "relay" mode where channels are switched only on or off depending on console fader position.

LOCATION AND ORIENTATION

THE UNIT SHOULD BE OPERATED HORIZONTALLY WITH THE OPERATOR PANEL FACING FORWARD OR BACKWARD (NOT UP OR DOWN).

Make certain the ventilation holes on the face of the unit are not obstructed. A six inch clearance should be maintained between the unit and other surfaces to ensure proper cooling. Do not place the DB-624 where it will be exposed to moisture or excessive heat. The DB-624 is intended for indoor use only.

MOUNTING

The DB-624 is designed to be mounted on truss equipment using standard lighting pipe clamps. The attaching bolt for these clamps will fit in into an inverted "T" slot located along the bottom of the dimmer. The slot will also accommodate a 1/2" bolt (3/4" across bolt head flats). Use pipe clamps to mount the DB-624 above a truss bar.

MOUNTING ADAPTERS

The DB-624 is supplied with three mounting adapters and their associated hardware. The primary purpose of the adapters is to provide a way to install the unit below a truss bar without turning it upside down. The adapters can also be used for other user defined mounting arrangements.

TO INSTALL THE MOUNTING ADAPTERS

1. Install a pipe clamp on the end of the adapter which overlaps itself. Make the clamp snug but not tight against the adapter so you can make final adjustments when installing the unit on a bar.
2. Install 1/2" bolt and flat washer through the other end of the adapter so that the bolt head and washer are inside the adapter.
3. Slide the adapter (with the 1/2" bolt and flat washer installed) on either end of the DB-624 so that the bolt head slides into the DB-624 "T" slot. The flat washer must be between the DB-624 and the adapter.
4. Install a lock washer and nut on the 1/2" bolt. Leave it loose enough to slide the adapter along the "T" slot in the DB-624.
5. Slide the adapter along the DB-624 "T" slot to the desired position and tighten the nut until it is snug. You may not want to completely tighten the nuts so you can make final adjustments when you hang the unit.

An illustration of the adapter installation appears on the following page.

6. Repeat the above process for the remaining adapters.
7. Hang the entire assembly on a truss bar by the pipe clamps. Tighten down any connections left loose during the previous assembly process.

NOTE: Use of safety chains or cables is recommended for any overhead dimmer installation

DB - 624 LIGHTBAR DIMMER OWNERS MANUAL

Version: 0.6

09/19/2008

MOUNTING ADAPTER INSTALLATION

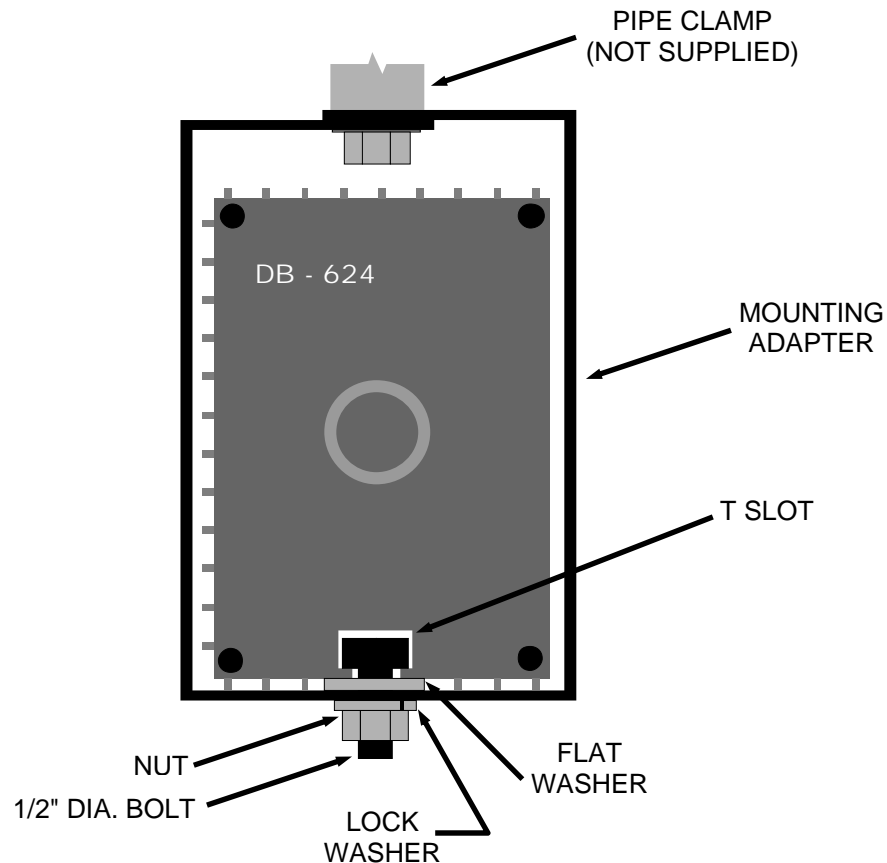

POWER REQUIREMENTS

Each DB-624 requires both lines of a SINGLE PHASE 120/240 VOLT AC service at 60 Amps per line or THREE PHASE 120/208 VOLT AC service at 40 Amps per line. A neutral conductor is needed. The unit requires a line frequency of 60HZ. Power enters the DB-624 through the knockout sized holes in the left end of the unit. A terminal block for connecting the incoming power is located inside the left end of the unit. There is also an earth ground lug.

The DB-624 will not operate correctly using only 2 phases of a 3 phase power service. This holds true regardless of whether the unit is set up for single or three phase power.

INSTALLATION

MAKE SURE THE INPUT POWER IS DISCONNECTED BEFORE INSTALLING THE DB-624.

The DB-624 is supplied to operate on THREE PHASE 120/208 VAC power. It can be "field converted" to operate on SINGLE PHASE 120/240 VAC. See the section "SINGLE PHASE POWER CONNECTIONS" for information about converting to single phase power. The power input terminals are rated for 3 AWG#10 wires, 4 AWG#12 wires or 5 AWG#14 wires. Terminal torque is 16 lb-in max.

DB - 624 LIGHTBAR DIMMER

Version: 0.6

OWNERS MANUAL

09/19/2008

KNOCKOUTS

Power access to the DB-624 is through the left end cover plate which has dual knockouts. The right end cover plate also has dual knockouts which "punch out" in the opposite direction. These end cover plates may be exchanged to accommodate your particular installation.

CONVERTING TO RIGHT HAND END POWER ACCESS

The DB-624 may be field converted to provide power connection access at the right hand end of the unit while retaining correct orientation of the center control panel. This is done by removing the center control panel and reinstalling it upside down. When this is done, the power input will be at the right end, The control panel will still read "right side up", and the channel outputs will correctly correspond to the labeling.

The procedure is as follows:

1. Remove the 6 screws which attach the center panel to the main chassis and carefully pull the panel out. Note the orientation of the two 6 pin, in line, connectors which connect to the rear center of the control circuit card.
2. Disconnect the two 6 pin inline connectors (depress the latching tabs to release them). On the circuit card these are labeled as J1 (upper) and J2 (lower). Also disconnect the 2 pin inline connector
3. Rotate the center control panel so it reads upside down and reinstall the 6 pin connectors. Do not rotate or move the female connectors which have wires in them. The connector which was attached to J1 should now connect to J2 and vice versa.
4. Reconnect the 2 pin inline connector and reinstall the control panel.

3 PHASE POWER CONNECTIONS

True 3 phase power must be supplied to operate the DB-624 in the 3 phase configuration. This means that each of the three input power hot legs (L1, L2, L3) must have a 120 degree electrical phase offset from each other. The feed circuit must be able to supply 40 Amps for each hot leg.

The DB-624 is factory shipped to accommodate THREE PHASE, 120/208, Y power service. Consult the applicable electrical codes for your location for exact wire specifications. The unit must be powered from a circuit providing a minimum of 40 Amps per line (3 pole 40 Amp circuit breaker). The minimum wire size is AWG#8. Wire may be either stranded or solid. The terminals are intended for copper wire only.



MAKE CERTAIN THAT THE INPUT POWER SOURCE IS
DE-ENERGIZED BEFORE MAKING CONNECTIONS.



CONNECT POWER WIRES AS FOLLOWS

- 1 Remove the access cover at the end of the unit.
- 2 Connect the 3 "HOT" power input wires to the L1, L2, L3 terminals.
- 3 Connect the neutral wire to the terminal marked N.
- 4 Connect a ground wire to the CHASSIS GROUND terminal marked G.

When operating the on three phase power, the DB-624 expects a particular phase sequence for these 3 input power connections. It does not matter which phase is connected to the L1 terminal but L2 and L3 must be in the correct order. The unit will not be damaged if these two connections are reversed but dimming will not occur correctly and some channels will appear to be in a on/off mode. If this occurs – see the "Phase Sensing Jumper" section in this manual and set the jumper block for 3 phase reverse operation.

A diagram of three phase power connections is shown below.

THREE PHASE POWER INPUT CONNECTIONS

Factory Supplied Configuration

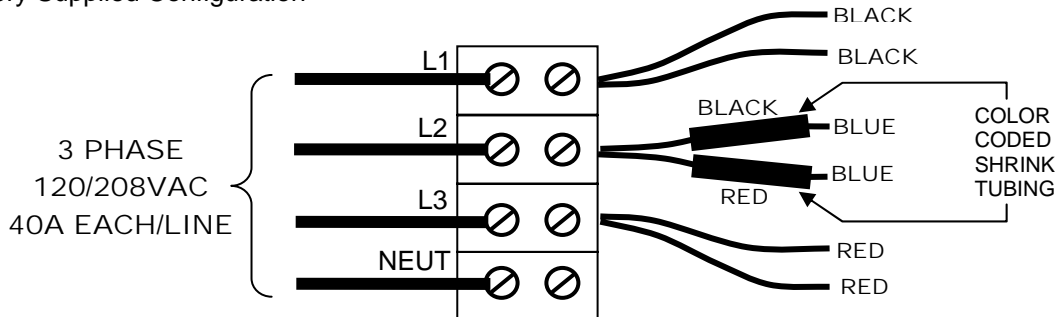

SINGLE PHASE POWER CONNECTIONS

The DB-624 may be field converted to accommodate a SINGLE PHASE 120/240 power service. Consult the applicable electrical codes for your location for exact wire specifications. The unit must be powered from a circuit providing a minimum of 60 Amps per line (2 pole 60 Amp circuit breaker). The minimum wire size is AWG#6. Wire may be either stranded or solid. The terminals are intended for copper wire only.



MAKE CERTAIN THAT THE INPUT POWER SOURCE IS DE-ENERGIZED BEFORE MAKING CONNECTIONS.



- 1 Remove the access cover at the end of the unit.
- 2 Connect the 2 "HOT" power input wires to the L1 and L3 terminals.
Note that the terminal marked L2 is not used for single phase operation.
- 3 Connect the neutral wire to the terminal marked N.
- 4 Connect a ground wire to the CHASSIS GROUND terminal marked G.

There are two blue wires in the L2 terminal on the opposite side of the power input terminal strip. These wires have color coded shrink tubing markers on them. One of them is marked with BLACK. The other is marked with RED.

- 5 Move the BLUE wire with the BLACK marker from the L2 terminal to the L1 terminal.
- 6 Move the BLUE wire with the RED marker from the L2 terminal to the L3 terminal.

A diagram of single phase power connections is shown below :

SINGLE PHASE POWER INPUT CONNECTIONS

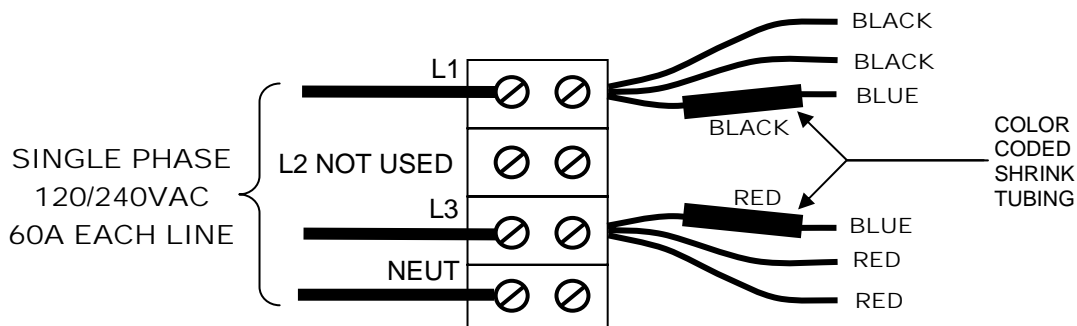

PHASE SENSING JUMPER

There is a small black jumper block located on the back of the control circuit board which must be set to correspond to either single phase, or 3 phase AC input power. Install the jumper according to the power at your facility using the diagram below. The positions are shown below and are marked on the circuit board. The control circuit board is mounted in the inside of the main control panel which is the front center panel on the unit. The 3 Phase Reverse setting is provided only to correct "out of sequence" power input connections. Also see the section "Three Phase Power Connections for more information concerning the 3 Phase Reverse setting.

The DB-624 is usually shipped from the factory set for 3 Phase Normal operation.

Disconnect or turn off power to the unit before changing jumper settings

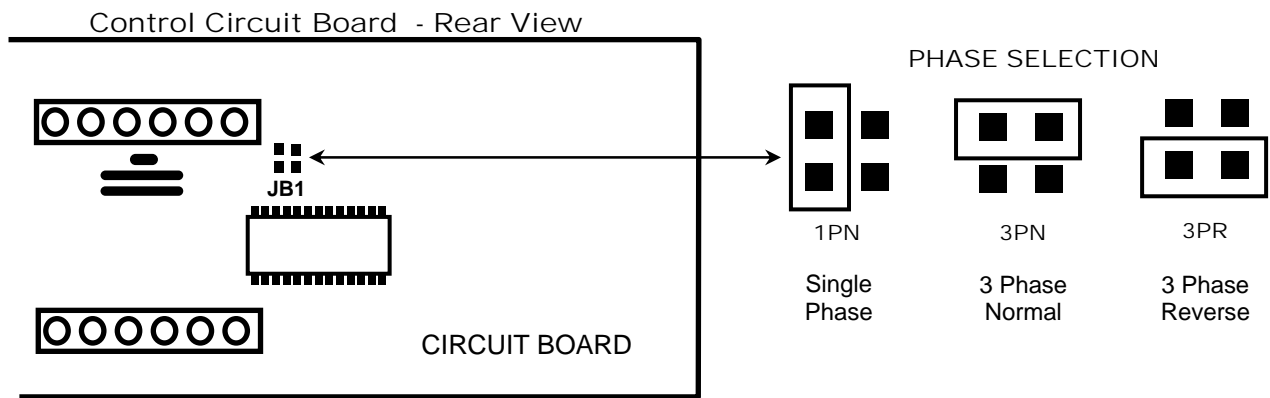

CHANNEL OUTPUT CONNECTIONS (LAMP LOAD CONNECTIONS)

Dimmer channel output connectors are on the face of the unit. Two connections are available for each channel (the optional twist-lock panels have one connection per channel). The numbering for the channels is shown on the unit center faceplate. The maximum load for each channel is 2400 Watts or 20 Amps.

CONTROL SIGNAL

The DB-624 is intended to be used with a control console which has been UL-508 Certified or uses only Low Voltage power. This ensures that any cabling or other power anomalies will not damage the DB-624 or your console.

Connect a Lightronics or other USITT DMX-512 compatible control console to the DB-624 using the MALE 5 pin XLR connector located on the center faceplate of the unit. This connector is marked DMX IN. The FEMALE 5 pin XLR connector is provided so you can connect multiple dimmers as a system. This connector is marked DMX OUT and will pass the DMX signal through to additional dimmers on a chain. Connector wiring information is given below.

PIN NUMBER	SIGNAL NAME
1	DMX Common
2	DMX Data -
3	DMX data +
4	Not Used
5	Not Used

DB - 624 LIGHTBAR DIMMER

Version: 0.6

OWNERS MANUAL

09/19/2008

DMX TERMINATION

A DMX device chain should be electrically terminated at the last device (and only the last device) on the control chain. A DMX terminator consists of a 120 Ohm resistor connected across the DMX DATA + and DMX DATA - lines. The DB-624 contains a built in terminator which may be switched in or out. The left end DIP switch on the unit center panel will apply the terminator if moved to the UP position.

OPERATION

CIRCUIT BREAKERS

A small plate near one end of the unit contains a 20 Amp magnetic circuit breaker for each dimmer channel. To operate a channel the associated circuit breaker must be closed. Channel numbers for the circuit breakers is located on the circuit breaker panel. If the circuit breaker will not remain closed then there is an overload at the lamps for that channel which MUST be corrected before operation can continue.

INDICATORS

There is a neon lamp for each channel on the center faceplate. This lamp indicates when INPUT power is available for the channel (Input power on and channel circuit breaker closed). There is also a row of 6 red LED's on the center faceplate which give an approximate indication of the channel output intensity.

SETTING THE UNIT STARTING ADDRESS

The DB-624 may be addressed to any block of 6 DMX addresses between 1 and 507. Set the rotary decade switches on the unit center panel to the number corresponding to the DMX address which will be used for the first channel of the DB-624. The remaining 5 channels will be assigned to consecutive higher DMX channels. Multiple DB-624's may be set to the same address block.

CHANNEL TESTING

DB-624 channel operation may be tested at the unit. The six small pushbuttons at the lower right of the center faceplate will activate the associated dimmer channel to full ON and OFF when pushed. In addition to channel testing, this function is useful when adjusting or focusing lamps. A channel which has been turned on by the test buttons can be turned back off at the DMX console by setting the associated channel fader to full ON and then back OFF. The red LED indicators located directly above the buttons indicate when the channel is on.

RELAY MODE OPERATION

Individual channels of the DB-624 may be switched into the relay mode. In this mode the dimmer channel will either be fully on or fully off depending on the channel intensity setting at the control console. The channel will remain off until a console fader position threshold point is crossed. When this occurs - the corresponding dimmer channel will switch to a full on condition. This mode is useful to control lamps and other lighting devices which cannot be dimmed.

There is a block of 7 DIP switches on the center panel of the unit. The right hand 6 of these switches is used to switch the corresponding channel into the relay mode. To switch a channel to the relay mode - push its DIP switch UP.

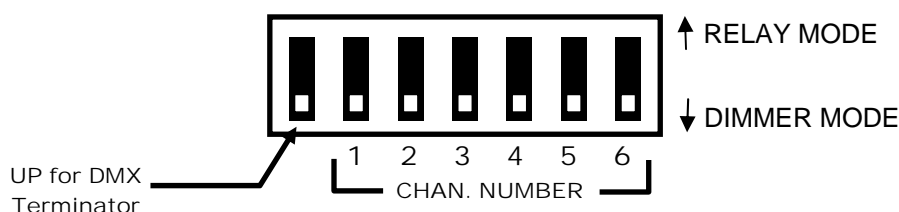

DB - 624 LIGHTBAR DIMMER

Version: 0.6

OWNERS MANUAL

09/19/2008

MAINTENANCE AND REPAIR

TROUBLESHOOTING

VERIFY THAT ALL POWER IS REMOVED BEFORE HANDLING THE UNIT.

- Verify that the unit channel addresses are correctly set.
- Check that the console is powered and that console channels are correctly patched or set.
- Check the control cable between the dimmer and its console.
- Verify the loads and their connections.

OWNER MAINTENANCE

There is one fuse in the unit which provides protection for the unit's printed circuit board . It may be replaced only with a 1/2 Amp, 250VAC, Fast acting replacement fuse.

There are no other user serviceable parts inside the unit.

The best way to prolong the life of your unit is to keep it cool, clean, and dry. It is important that the cooling intake and exit vent holes are clean and unobstructed.

Service by other than Lightronics authorized agents may void your warranty.

OPERATING AND MAINTENANCE ASSISTANCE

If service is required, contact the dealer from whom you purchased the equipment or return it to the Lightronics Service Department, 509 Central Drive, Virginia Beach, VA 23454. TEL 757 486 3588. All items returned for service must include a description of the problem along with your name, address, and phone number.

Lightronics recommends that you record the serial number of your DB-624 for future reference.

SERIAL NUMBER _____

SPECIFICATIONS and FEATURES

Channels/Capacity	6 channels @ 2400 watts/chan	Local Control	On board test button for each channel.
Power Input	120/240VAC Single Phase, 60 Amps	Relay Mode	Switchable by individual channel
	120/208VAC Three Phase, 40Amps	Addressing	Starting channel can be set to any of 512 channels.
Control Protocol	USITT DMX-512	Size	72" x 5" x 3"
Filtering	450 usec. minimum	Weight	26 Lbs
Overload Protection	20 Amp, fast acting, magnetic circuit breaker for each channel		



All Lightronics products are warranted for a period of TWO/FIVE YEARS from the date of purchase against defects in materials and workmanship.

This warranty is subject to the following restrictions and conditions:

- A) If service is required, you may be asked to provide proof of purchase from an authorized Lightronics dealer.
- B) The FIVE YEAR WARRANTY is only valid if the warranty card is returned to Lightronics accompanied with a copy of the original receipt of purchase within 30 DAYS of the purchase date, if not then the TWO YEAR WARRANTY applies. Warranty is valid only for the original purchaser of the unit.
- C) This warranty does not apply to damage resulting from abuse, misuse, accidents, shipping, and repairs or modifications by anyone other than an authorized Lightronics service representative.
- D) This warranty is void if the serial number is removed, altered or defaced.
- E) This warranty does not cover loss or damage, direct or indirect arising from the use or inability to use this product.
- F) Lightronics reserves the right to make any changes, modifications, or updates as deemed appropriate by Lightronics to products returned for service. Such changes may be made without prior notification to the user and without incurring any responsibility or liability for modifications or changes to equipment previously supplied. Lightronics is not responsible for supplying new equipment in accordance with any earlier specifications.
- G) This warranty is the only warranty either expressed, implied, or statutory, upon which the equipment is purchased. No representatives, dealers or any of their agents are authorized to make any warranties, guarantees, or representations other than expressly stated herein.
- H) This warranty does not cover the cost of shipping products to or from Lightronics for service.
- I) Lightronics Inc. reserves the right to make changes as deemed necessary to this warranty without prior notification.

