



# TL - 5024

## MEMORY LIGHTING CONSOLE

### OWNERS MANUAL

Revision 0.92

05/15/2009

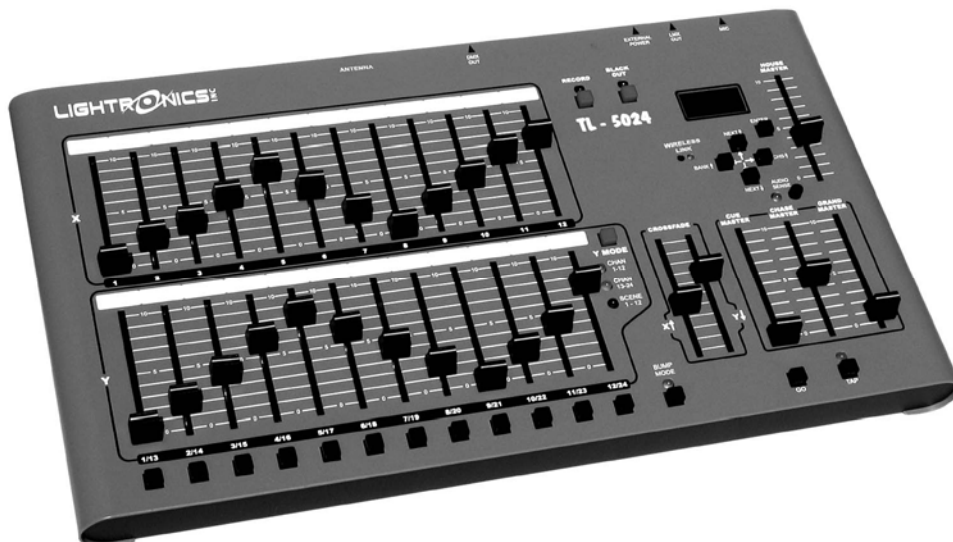

**TL-5024 LIGHTING MEMORY CONSOLE**

Revision 0.92

OWNERS MANUAL

05/15/2009

**SPECIFICATIONS**

- Total channels 12 or 24 depending on mode
- Operating modes 12 channels x 2 manual scenes  
24 channels x 1 manual scene  
12 channels + 12 recorded scenes
- Scene memory 12 scenes per bank x 16 banks  
192 total scenes
- Chase 12 programmable 20 step chases
- Control protocol LMX-128 (multiplex)  
USITT DMX-512 is optional
- Output connector 3 pin XLR connector  
5 pin XLR for DMX-512
- Compatibility Multiplex protocol compatible with other multiplexed systems
- Power input 18VAC or +15VDC  
Optional external power supply
- Dimensions 16.25"W X 9.25"H X 2.5"H
- Weight 6.8 pounds

**CONSOLE DESCRIPTION AND FEATURES**

The TL-5024 is a 24 channel lighting control console which includes advanced features such as multiple scene banks, softpatching, multiple user programmable chases, and a LCD Status Display.

The TL-5024 may be powered by the dimmers it is controlling which eliminates the need for nearby AC power. The unit may also be powered by an external power supply.

The TL-5024 transmits the LMX-128 multiplex lighting control protocol. This signal is compatible with other industry standard multiplex signals. The unit can be factory equipped to transmit the USITT DMX-512 protocol as an option. The DMX-512 option can be factory retrofitted to existing units or supplied as a kit for user installation.

The TL-5024 transmits 256 channels of DMX-512 and 64 channels of LMX-128.

**INSTALLATION**

The TL-5024 control console should be kept away from moisture and direct sources of heat.

**LMX CONNECTIONS**

Connect the unit to a Lightronics (or compatible) dimmer using a multiplex control cable with 3 pin XLR connectors. The TL-5024 is powered by the dimmer which it is connected to. It may also be powered via an optional external power supply. The unit will operate with dimmers in both the NSI/SUNN and Lightronics modes. All dimmers connected to the unit **MUST** be in the SAME mode.

LMX-128 Connector Wiring  
(3 PIN FEMALE XLR)

PIN #	SIGNAL NAME
1	Common
2	Phantom power from dimmers Normally +15VDC
3	LMX-128 multiplex signal

**DMX CONNECTIONS**

Connect the unit to a DMX dimmer using a control cable with 5 pin XLR connectors. The DMX-512 connection does NOT provide console power therefore an external power supply (provided with units having DMX option) must be used. There is more information about external power supplies at the end of this manual.

DMX-512 Connector Wiring  
(5 PIN FEMALE XLR)

PIN #	SIGNAL NAME
1	Common
2	DMX data -
3	DMX data +
4	Not Used
5	Not Used

CONTROLS AND INDICATORS

- X Faders: Control individual channel levels for channels 1 – 12.
- Y Faders: Control level of scenes or individual channels depending on current operating mode.
- Cross Faders: Fade between X and Y row faders.
- Bump Buttons: Activates associated channels at full intensity while pressed.
- TAP Button: Press three or more times at desired rate to set chase speed.
- TAP Indicator: Flashes at currently set chase rate.
- AUDIO SENSE Knob: Adjusts sensitivity of the microphone for chase rate control.
- Y Mode Indicators: Indicate current operating mode of Y faders.
- Y Mode Button: Selects operating mode of Y faders.
- BLACKOUT Button: Turns on and off console output from all scenes, channels and chases.
- BLACKOUT Indicator: Lighted when blackout is active.
- Cue Master: Adjusts the intensity of cues.
- Chase Master: Adjusts the intensity of running chase patterns.
- Grand Master: Adjusts output level of all console functions.
- House Master: Adjusts intensity of dimmer channels assigned to console channel number 99.
- Record Button: Records scenes and chase patterns.
- Record Indicator: Flashes when chase or scene recording is active.
- Bump Mode Button: Converts channel bump buttons between pile-on and solo operation.
- Bump Mode Indicator: Lighted if bump mode is solo.
- GO Button: Activates the next cue in the cue list.
- ENTER Button: Activates and executes selections in the menu system.
- Arrow Buttons: Select current Scene Bank, Chase Pattern, and number of next Cue. Also used with the menu system.

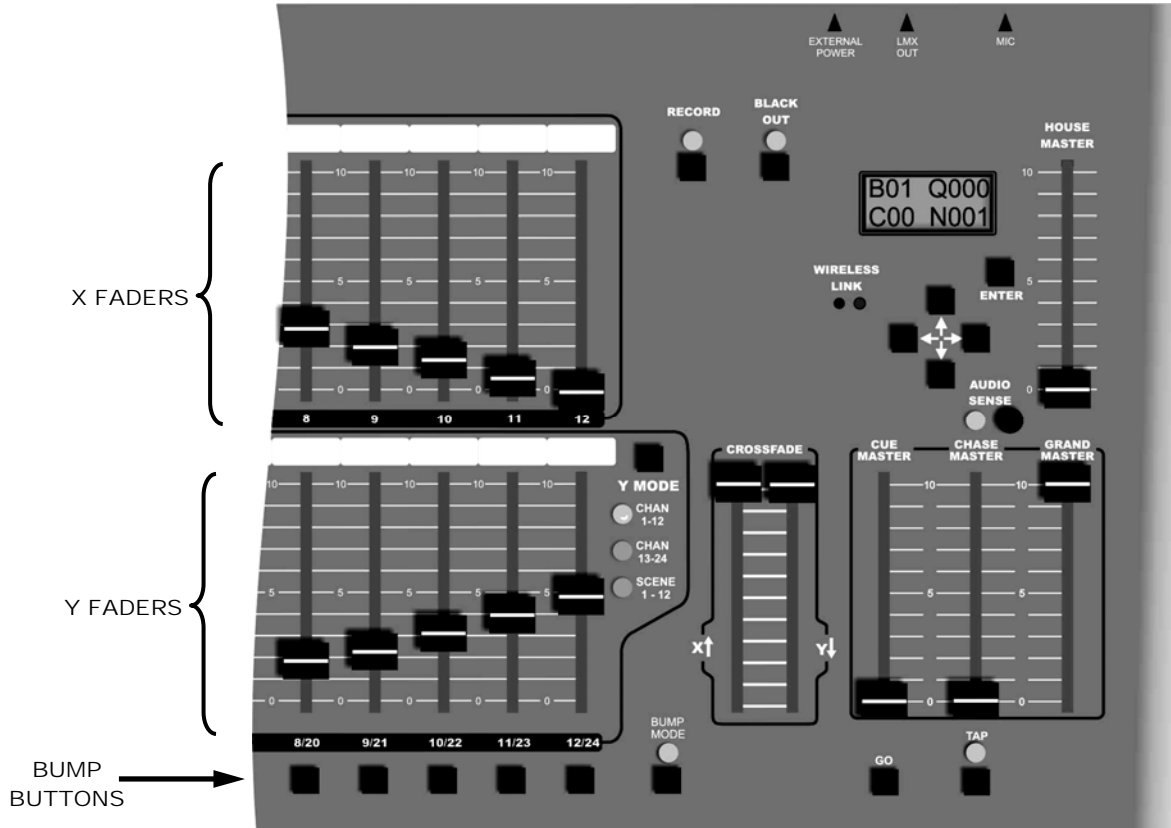

## TL-5024 LIGHTING MEMORY CONSOLE

Revision 0.92

OWNERS MANUAL

05/15/2009

## SETUP AND PRELIMINARY OPERATION

## CONSOLE RESET

The TL-5024 can be set to factory default conditions by performing an ERASE ALL function which is accessed from the LCD menu. ERASE ALL causes the following actions:

1. The cue list will be set to the default values.
2. Chase step scene assignments will be set to the default scenes. Channel settings will be set OFF.
3. All channels of all scenes in all banks will be set to zero intensity (scenes will be erased).
4. The softpatch will be set to a one to one assignment. Patch page 1 will be made active.

## OPERATION

## OPERATING MODES

The TL-5024 is capable of operating in three different modes concerning the Y faders. Pressing the "Y MODE" button changes the function of the Y (lower 12) faders. The selected mode is indicated by the Y mode LEDs. The X (upper 12) faders ALWAYS control the level of channels 1 through 12.

- "CH 1-12" In this mode both the X and Y rows of faders control channels 1 through 12. The cross faders are used to transfer control between X and Y.
- "CH 13-24" In this mode the Y faders control channels 13 through 24.
- "SCENE 1-12" In this mode the Y faders control the intensity of 12 recorded scenes.

## GENERAL OPERATION OF CONTROLS

**GRAND MASTER:** The grand master fader controls the output level of all functions of the console except the HOUSE MASTER.

**CROSS FADERS:** The cross fader provides the ability to fade between the upper (X) faders and the lower (Y) faders. The cross fade function is split into two parts giving you the ability to control the level of the upper and lower groups of faders individually. In all modes, the X cross fader must be UP to activate the upper faders and the Y cross fader must be DOWN to activate the lower faders.

**BUMP BUTTONS:** These momentary buttons activate channels 1 through 12 at full intensity when pressed. The master fader affects the level of channels activated by the bump buttons. Bump buttons are not latching. When you release a bump button the associated channel returns to its previous state.

**BUMP MODE BUTTON:** The bump buttons may be operated in 2 different modes. This button switches between these modes. In the pile-on mode pushing a bump button will force the associated channel to full intensity overriding the channel fader setting. In the solo mode the bump buttons force the associated channel to full intensity AND force all other channels off.

**CHASE MASTER FADER:** The chase master controls the overall intensity of chase patterns.

**CUE MASTER FADER:** The cue master fader controls the overall intensity of scenes activated by the cue list.

**BLACKOUT BUTTON:** Pressing the blackout button causes all channels, scenes, chases, and cues to go to zero intensity. The blackout LED will light whenever the console is in blackout mode.

**TAP BUTTON:** Press 3 or more times at the desired rate to set chase speed. TAP LED will flash at the selected rate.

**RECORD BUTTON:** Executes recording of scenes and chase patterns. RECORD LED will light when in recording is active.

**HOUSE MASTER FADER:** The house master is an extra channel fader which will control the intensity of any/all dimmer channels assigned as console channel 99. It is used to enable control of the house lights from the lighting console in situations where the house lights are included in the dimmer system.

## TL-5024 LIGHTING MEMORY CONSOLE

Revision 0.92

OWNERS MANUAL

05/15/2009

## STATUS DISPLAY

The diagram below shows what information is given on the status display during normal operation. When the menu system is in use then other information will be shown.

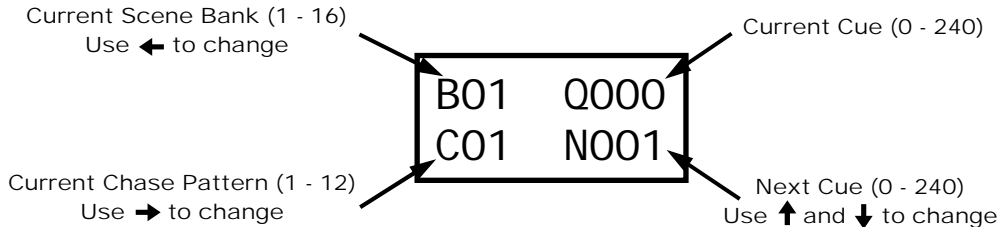

## CHANNEL ASSIGNMENTS (PATCHING)

You can assign dimmer channels to console channels in other than a 1 to 1 correspondence. For instance you may want to have the lights connected to dimmer channels 1 and 2 assigned to console fader 3. (You can have several dimmer channels patched to a single console fader but you cannot assign a dimmer channel to more than 1 console channel at a time.) This set of channel assignment or "patch" information can be saved in the console as a "patch page".

## PATCH PAGES

The TL-5024 contains 2 patch pages. In other words you can have two complete sets of channel assignments in the console and switch between them. In situations where the console is used for different applications, multiple patch pages can save time that would be spent re-patching each channel for a given application. The current patch page may be toggled between the two pages by using the MENU system.

## DEFAULT CHANNEL ASSIGNMENTS

The TL-5024 is provided with a default channel assignment set for patch page 1. This assignment results in a 1 to 1 patch for dimmer channels 1 - 24. The pattern is repeated beginning at dimmer channel 25 (It is assigned to console channel 1 again). The repeat continues up to dimmer channel 256.

The default for patch page 2 is all channel assignments completely cleared.

## TO CHANGE THE CURRENT PATCH PAGE

1. Push ENTER ↓ ↓ ↓ ENTER ↓ to access the PATCH submenu. The following display will appear with the page number (1 or 2) flashing.

PAGE=1	→
REPATCH	

2. Use the → button to change the number.

## ASSIGNING CURRENT PATCH PAGE CHANNELS

Channel assignments are always applied only to the currently selected patch page.

1. Push ENTER ↓ ↓ ↓ ENTER ↓ ↓ ENTER to access the REPATCH submenu. The following display will be shown.

DIM ← →	001
CON ↑ ↓	01

The top row shows a dimmer channel number. The bottom row shows the console channel (fader) to which the dimmer channel number is assigned. Use the → and ← buttons to cycle through the dimmer channel numbers. The assigned console channel will be shown for each one. You can change the console channel number with the ↑ and ↓ buttons.

You can assign more than one dimmer channel to any console channel. A dimmer channel cannot be assigned to multiple console channels. In other words - any particular dimmer can be assigned to only one console channel.

## TL-5024 LIGHTING MEMORY CONSOLE

Revision 0.92

OWNERS MANUAL

05/15/2009

You can assign a dimmer channel to console channel 00. If you do this, then that dimmer channel will not respond to the console.

You can also assign a dimmer channel to console channel 99..If you do this, then the dimmer channel will be controlled by the HOUSE MASTER fader. Multiple dimmer channels can be assigned to the house master.

You can perform three other operations from the PATCH menus.

1. You can copy the contents of either patch page to the other one.
2. You can set a 1 to 1 patch condition for the current page.
3. You can ZERO ALL channel assignments for the current patch page. This removes ALL assignments.

#### RECORDING SCENES

The TL-5024 can store 192 scenes. Each scene contains all 24 channels. The scene memory is organized as 16 banks with 12 scenes in each bank.

To record a scene:

1. Select the bank into which the scene will be stored by pushing the ◀ button. The current scene bank is shown in the upper left corner of the LCD STATUS display and advances as the button is pushed.
2. Set the faders to the desired intensities for the scene (create the scene).
3. Push the RECORD button. The RECORD indicator will begin flashing.
4. Push one of the 12 bump buttons (below the lower fader row) to store the scene. The number of the button pushed (1-12) is the scene number within the bank selected in step 1. The record indicator will go off.

#### SCENE PLAYBACK

1. Select the bank for the scene you want to activate by pushing the ◀ button. The current scene bank is shown in the upper left corner of the LCD STATUS display and advances as the button is pushed.
2. Activate the SCENE 1-12 mode for the Y faders.
3. Raise a Y fader (1 - 12) to activate its associated scene in the bank. Multiple scenes may be added together by raising more than 1 fader.

#### CHASER FUNCTIONS

A chase is a sequence of complete scenes which runs, automatically, at a user selected speed. The scenes must be created and stored in the unit scene memory before use. The channels in each scene will appear at the recorded intensity when the chase is played.

A chase may also be a sequence of specific channel selections to be on for each step.

The TL-5024 provides 12 chases. Each chase may have up to 20 steps. All steps of all chases are user created. Combinations of scenes and channel settings may be used in chase steps.

#### DEFAULT CHASE SETTINGS

The TL-5024 has a default set of scene assignments and channel intensities for chase operations. These are the assignments which will be set if the ERASE ALL or ERASE CHASER functions are invoked from the ERASE menu.

Default scene assignments for chase steps are set to the first 12 scenes in each bank starting at bank 01. In other words chase 01 uses the first 12 scenes in bank 01. Chase 02 is set to the first 12 scenes in bank 02. Chase steps beyond step 12 are set to "END" which means that the chase will "wrap around" back to the first step after step 12. You can program any chase to use all 20 steps if needed.

A complete table of default chase step assignments is provided at the end of this manual.

## TL-5024 LIGHTING MEMORY CONSOLE

Revision 0.92

OWNERS MANUAL

05/15/2009

## RECORDING CHASES

1. Push ENTER ↓ ↓ ENTER ↓ to access the CHASER submenu. The following display will appear.

```

C01   S01
EDIT

```

The chase which is to be programmed is shown in the upper left (C01 meaning chase 01). The step number within the chase is shown in the upper right (S01 meaning step 01). The item on the bottom row (EDIT) will access a submenu enabling you to edit that chase/step number.

Use the ← and → buttons to select one of the choices. The choice will flash when selected. For the chase number and step number - use the ↑ and ↓ buttons to change the number.

2. Push ENTER when EDIT is selected to program or edit the contents of the chase step. The following display will appear:

```

BNK: SCN →
01: 01  ↕

```

3. Use the ↑ and ↓ buttons to change the step to another bank:scene number. You can select bank 00:scene 00. This selection will cause all scenes to be off for the step.

You can force the chase to start over (wrap around) at any given step by pushing the ↓ button until END appears.

4. You can also select individual channels to be ON or OFF for the chase step by push the → button. The following display will appear:

```

← CHN: 01 →
OFF  ↕

```

Use the ← and → buttons to cycle through the channels (1 - 24) and use the ↑ and ↓ buttons to turn the channel ON or OFF for the step.

Channels turned on from this menu will override any scene settings for the channel when the chase is played.

## CHASE PLAYBACK

1. The currently selected chase is indicated in the lower left section of the LCD STATUS display. Use the → button to change to another chase.

You can turn off the chaser function by selecting chase 00. The TAP LED will not blink when chase 00 is selected.

2. Push the TAP button 3 or more times at the same rate that you want the chase to run.
3. Raise the CHASE MASTER fader to make the chase visible at the lights. Chases are added into manual fader settings and active scenes.

## AUDIO DRIVEN CHASE

The chase rate may be controlled by an internally mounted microphone. The microphone picks up sounds nearby and circuitry in the TL-5024 filters out all but low frequency sounds. The result is that the chase will synchroznize with base notes of music being played nearby.

Rotate the AUDIO SENSE control clockwise to increase the sensitivity of the microphone. This function is disabled when AUDIO SENSE is turned fully counterclockwise.

## USING CUE LISTS

After you have created and saved scenes in the TL-5024, you can put them into a scene cue list. Once the cue list has been created, you can “play” the list by pushing the GO button. Pushing this button causes the current cue scene to fade out and the next scene to fade in. The list contains 240 cues. Any cue may point to any scene in any bank. Each entry in the cue list contains the bank number of a scene, the scene number within that bank, a “fade in” time, and a “fade out” time. The “fade out” time is the number of seconds the PREVIOUS cue scene will take to fade out as the current cue scene fades in. You can adjust both of these times to obtain various effects. Fade times can range from 0 to 99 seconds.

## TL-5024 LIGHTING MEMORY CONSOLE

Revision 0.92

OWNERS MANUAL

05/15/2009

The overall brightness of cues is controlled by the CUE MASTER fader. Cues are affected by the BLACKOUT function and the GRAND MASTER fader. Cue number 0 is reserved as a blackout and is not programmable.

The LCD STATUS display always shows the current cue number in the upper right section and the next cue number in the lower right. Cues normally proceed in a sequential manner (cue 2 follows cue 1... etc.). You can alter the order of cue playback by using the ↑ and ↓ buttons. The display will indicate your entry as the next cue to be activated. When you push GO – this is the cue will fade in.

### DEFAULT CUE LIST

The TL-5024 is provided with a factory default cue list. This is the condition which will be set if the ERASE ALL or ERASE CUEING function is invoked from the ERASE menu. The settings for the default cue list are as follows:

Cues 1 - 12 are set to scenes 1 - 12 in scene bank 1.  
Cues 13 - 24 are set to scenes 1 - 12 in scene bank 2.  
Cues 25 - 36 are set to scenes 1 - 12 in scene bank 3.

This repeat continues until all 16 scene banks have been used. This occurs at cue number 192. Cues 193 through 240 are set to scene bank 0, scene 0. In other words they are not assigned.

### CREATING A CUE LIST

1. Push ENTER ↓ ENTER ↓ to access the cueing menu. The following Display will be shown.

CUE	BK01
001	SC01

The left side of the display shows the cue number being assigned. The upper right shows the bank number of the scene assigned to that cue. The lower right shows the scene number (within the bank) assigned to that cue.

2. Use the ← and → buttons to select one of the items (cue number, bank number, or the scene number). The item will appear flashing when selected.
3. Use the ↑ and ↓ buttons to change the value of the selected item.

To review cue assignments: Select the cue number and run it up and down. The bank/ scene assigned will be displayed as you cycle through the cues.

4. To set the "fade in" and "fade out" times for the cue: Push the → button until the following display appears:

CUE	FI 02
001	FO02

The cue number is shown on the left side of the display. The right side shows the fade in time in seconds on the top and the fade out time in seconds on the bottom.

5. Use the ← and → buttons to select one of the items (FI or FO). The item will appear flashing when selected.
6. Use the ↑ and ↓ buttons to change the value of the selected item.

### CUE LIST PLAYBACK

1. The next cue to be activated is shown in the lower right section of the LCD STATUS display. Use the ↑ and ↓ buttons to change the next cue selection.
2. Push the GO button. The next cue (selected in the step above) will be activated.

The overall intensity of cues is controlled by the CUE MASTER fader. Cues will not be visible if the CUE MASTER fader is down.

Individual channel fader settings and scenes are added into the cue in a "greatest of" manner. In other words if the cue sets a channel at 50% and the fader for that channel is at 100% then the resulting intensity for that channel will be 100%.

### ERASE FUNCTIONS

Erase functions are used to partially or fully reset the TL-5024 to its default (factory set) state. They can be invoked separately or as a group. There are four functions as follows:

1. ERASE CUEING: Returns the cue list to its default set of banks, scenes, and fade times.

## TL-5024 LIGHTING MEMORY CONSOLE

Revision 0.92

OWNERS MANUAL

05/15/2009

The current and next cue numbers are not altered.

2. ERASE CHASER: Returns the chase step assignments to the default set of banks, scenes and channel settings. The current chase number will not be altered.
3. ERASE SCENES: All channels of all scenes in all banks will be set to zero intensity. The current bank number will not be altered.
4. ERASE SOFTPATCH: Patch page 1 will be set to a 1 to 1 assignment and will become the active page. Patch page 2 will be completely cleared of all assignments.
5. ERASE ALL: Performs all 4 of the erase functions described above.

## USING ERASE FUNCTIONS

1. Push ENTER ↓ ↓ ↓ ↓ ENTER ↓. The display will show the ERASE CUEING menu.
2. Push ENTER to erase the cues. or Push ↓ to move to the next erase function.

Once in the erase menus you can use the ↑ and ↓ buttons to cycle through all of the erase function choices. When you activate an erase function you will see a display (shown below) which allows you to back out without actually completing the erase function.

Are You  
Sure? N →

The N means NO. Use the → button to change it to Y (yes) and push ENTER. The function will proceed.

## DMX OPERATION

If the DMX option is installed in the TL-5024 it will transmit both DMX and LMX signals simultaneously. The DMX-512 connection does NOT provide console power therefore an external power supply (provided with units having DMX option) must be used.

## TL-5024 WIRELESS OPTION

The TL-5024 can optionally be provided with an internal RF transmitter module which transmits the DMX-512 control signal. It can operate with multiple compatible wireless DMX dimmers and/or receivers. The receiver units get the the same information they would get using a cable connected to the TL-5024 DMX connector.

The wireless system uses the 2.45 GHz band and operates at low power (< 100mW). The operating range is approximately 1400 ft. indoors and about 4000 ft. for outdoor operation. This range could vary significantly depending on the surrounding conditions.

A link between a specific single wireless equipped TL-5024 and one or more compatible receiving units is invoked to enable wireless operation. The linking operation is performed at the TL-5024. Once linked, the receiver units can operate ONLY with that specific console. The link is retained even when the receiver and/or console are powered off. The receiver units may be released from the link either at the TL-5024 or at the receiver. If released at the console then ALL linked receivers will be released. If released at the receiver then ONLY that receiver will be released.

## ANTENNA CONNECTION

Carefully thread the antenna to the gold antenna connector on back edge of the unit. It should be finger tight only. The connectors can be damaged or jammed if too tight. The antenna will swivel to a convenient orientation while connected.

## OPERATION

A small pushbutton and a LED are located to the left of and below the main console LCD display. The button controls all wireless operation. The LED indicates wireless status.

## STATUS INDICATOR LED

The indicator shows wireless status as follows:

OFF	NO WIRELESS POWER
ON	TRANSMITTER OK
FLASH	LINKING IN PROGRESS
	or
	LINK RELEASE IN PROGRESS

## TL-5024 LIGHTING MEMORY CONSOLE

Revision 0.92

OWNERS MANUAL

05/15/2009

**LINK CONTROL BUTTON**

This pushbutton switch is used to link all free receiver units within its range. It is also used to release the links with all receivers in its range.

**LINKING RECEIVERS**

LINKS WILL NOT BE MADE WITH RECEIVERS ALREADY LINKED TO ANOTHER TRANSMITTER DEVICE.

Push the link control button once (do not hold down). The indicator LED will flash for about 10 seconds. It will then go to an ON state.

The link indicator on the receiver will also flash and may continue this for several more seconds after the console indicator goes back to ON. The link indicator on the receiver will go to an ON state when the link is stable.

**UNLINKING ALL RECEIVERS**

Hold the link control button down for about 5 seconds.

The indicator LED will go to a flash state for about 10 seconds then return to ON. The link indicator on the receiver unit(s) will go OFF.

Link release for a single receiver unit can only be performed at the receiver unit.

**MAINTENANCE AND REPAIR****TROUBLESHOOTING**

Check that the multiplex cable is not defective.

To simplify troubleshooting, reset the unit to provide a known set of conditions.

Make sure that the dimmer address switches are set to the desired channels.

**OWNER MAINTENANCE**

The best way to prolong the life of your TL-5024 is to keep it dry, clean, and covered when not in use.

The unit exterior may be cleaned using a soft cloth dampened with a mild detergent/water mixture or a mild spray-on type cleaner. DO NOT SPRAY ANY LIQUID directly on the unit. DO NOT IMMERSE the unit in any liquid or allow liquid to get into the controls. DO NOT USE any solvent based or abrasive cleaners on the unit.

The faders are not cleanable. If you use a cleaner in them – it will remove the lubrication from the sliding surfaces. Once this happens it is not possible to re-lubricate them.

The white strips above the faders are not covered by the TL-5024 warranty. If you mark on them with any permanent ink, paint etc. it is likely that you will be unable to remove the markings without damaging the strips.

**INTERNAL MAINTENANCE**

There are no user serviceable parts in the unit. Service by other than Lightronics authorized agents will void your warranty.

**EXTERNAL POWER SUPPLY INFORMATION**

The TL-5024 may be powered by an external supply with the following specifications:

Output Voltage:	13 to 25 Volts AC or DC
Output Current:	400 Milliamps
Connector:	2.1mm female connector

NOTE: If a DC Supply is used – the center pin must be the NEGATIVE voltage.

**OPERATING AND MAINTENANCE ASSISTANCE**

Dealer and Lightronics Factory personnel can help you with operation or maintenance problems. Please read the applicable parts of this manual before calling for assistance.

If service is required - contact your dealer or contact the Lightronics Service Dept.

USING THE MENUS

The TL-5024 uses a menu system to control four functions. They are the CUEING, CHASER, PATCH, and ERASE functions. Some menus have more than one display screen. The menus are accessed by pushing the ENTER button. The diagram below shows the overall layout of the menus. The arrow characters shown in some of the displays tell which button to push to change a value or advance to another item.

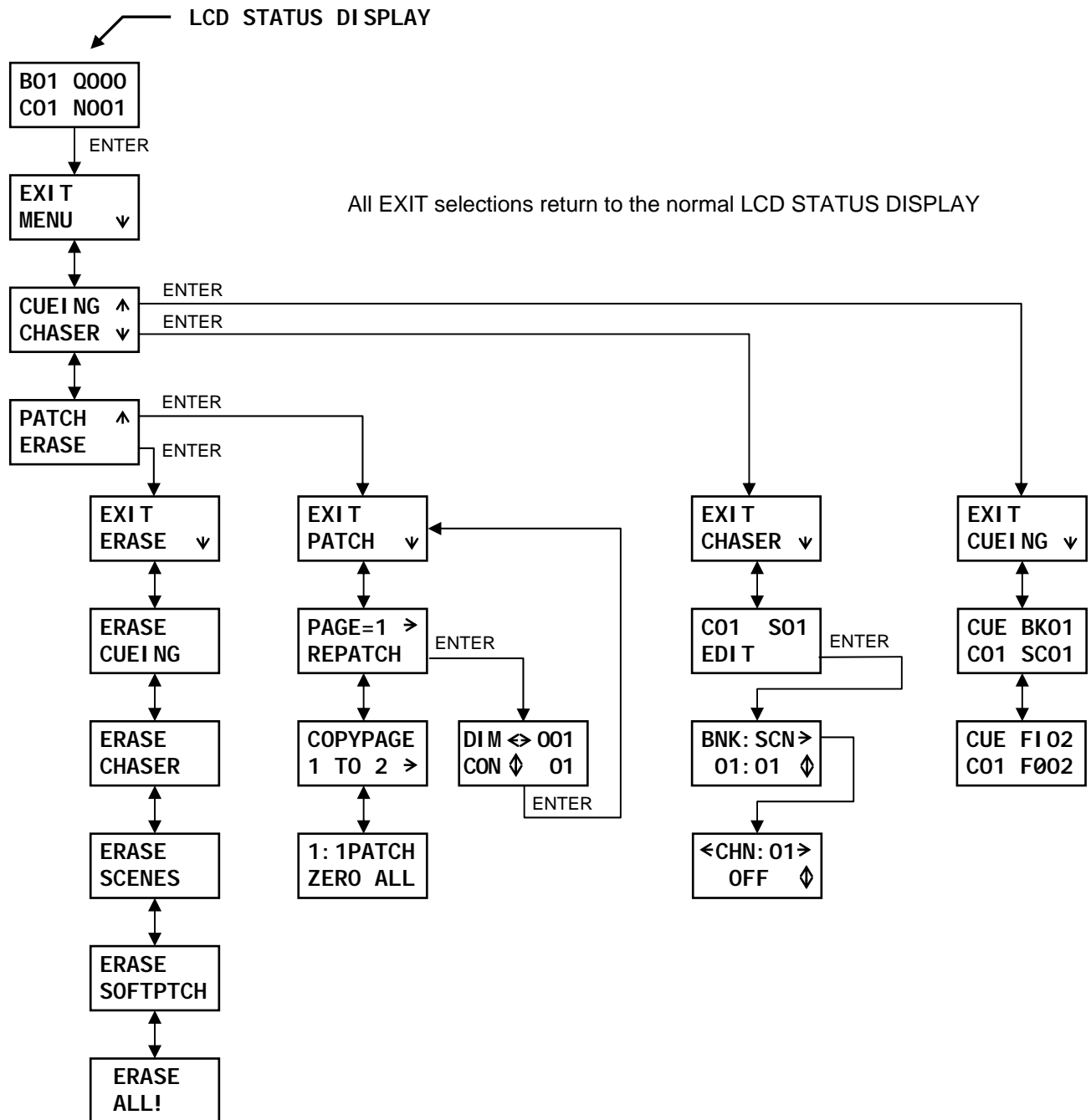

## TL-5024 LIGHTING MEMORY CONSOLE

Revision 0.92

OWNERS MANUAL

05/15/2009

## DEFAULT CHASE SCENE ASSIGNMENTS

The following assignments will be made when ERASE CHASER or ERASE ALL is run.

STEP #	CHASE NUMBER					
	1	2	3	4	5	6
1	B01 SC01	B02 SC01	B03 SC01	B04 SC01	B05 SC01	B06 SC01
2	B01 SC02	B02 SC02	B03 SC02	B04 SC02	B05 SC02	B06 SC02
3	B01 SC03	B02 SC03	B03 SC03	B04 SC03	B05 SC03	B06 SC03
4	B01 SC04	B02 SC04	B03 SC04	B04 SC04	B05 SC04	B06 SC04
5	B01 SC05	B02 SC05	B03 SC05	B04 SC05	B05 SC05	B06 SC05
6	B01 SC06	B02 SC06	B03 SC06	B04 SC06	B05 SC06	B06 SC06
7	B01 SC07	B02 SC07	B03 SC07	B04 SC07	B05 SC07	B06 SC07
8	B01 SC08	B02 SC08	B03 SC08	B04 SC08	B05 SC08	B06 SC08
9	B01 SC09	B02 SC09	B03 SC09	B04 SC09	B05 SC09	B06 SC09
10	B01 SC10	B02 SC10	B03 SC10	B04 SC10	B05 SC10	B06 SC10
11	B01 SC11	B02 SC11	B03 SC11	B04 SC11	B05 SC11	B06 SC11
12	B01 SC12	B02 SC12	B03 SC12	B04 SC12	B05 SC12	B06 SC12
13	END	END	END	END	END	END
14	END	END	END	END	END	END
15	END	END	END	END	END	END
16	END	END	END	END	END	END
17	END	END	END	END	END	END
18	END	END	END	END	END	END
19	END	END	END	END	END	END
20	END	END	END	END	END	END

STEP #	CHASE NUMBER					
	7	8	9	10	11	12
1	B07 SC01	B08 SC01	B09 SC01	B10 SC01	B11 SC01	B12 SC01
2	B07 SC02	B08 SC02	B09 SC02	B10 SC02	B11 SC02	B12 SC02
3	B07 SC03	B08 SC03	B09 SC03	B10 SC03	B11 SC03	B12 SC03
4	B07 SC04	B08 SC04	B09 SC04	B10 SC04	B11 SC04	B12 SC04
5	B07 SC05	B08 SC05	B09 SC05	B10 SC05	B11 SC05	B12 SC05
6	B07 SC06	B08 SC06	B09 SC06	B10 SC06	B11 SC06	B12 SC06
7	B07 SC07	B08 SC07	B09 SC07	B10 SC07	B11 SC07	B12 SC07
8	B07 SC08	B08 SC08	B09 SC08	B10 SC08	B11 SC08	B12 SC08
9	B07 SC09	B08 SC09	B09 SC09	B10 SC09	B11 SC09	B12 SC09
10	B07 SC10	B08 SC10	B09 SC10	B10 SC10	B11 SC10	B12 SC10
11	B07 SC11	B08 SC11	B09 SC11	B10 SC11	B11 SC11	B12 SC11
12	B07 SC12	B08 SC12	B09 SC12	B10 SC12	B11 SC12	B12 SC12
13	END	END	END	END	END	END
14	END	END	END	END	END	END
15	END	END	END	END	END	END
16	END	END	END	END	END	END
17	END	END	END	END	END	END
18	END	END	END	END	END	END
19	END	END	END	END	END	END
20	END	END	END	END	END	END



All Lightronics products are warranted for a period of TWO/FIVE YEARS from the date of purchase against defects in materials and workmanship.

---

- A) If service is required, you may be asked to provide proof of purchase from an authorized Lightronics dealer.
- B) The FIVE YEAR WARRANTY is only valid if the warranty card is returned to Lightronics accompanied with a copy of the original receipt of purchase within 30 DAYS of the purchase date, if not then the TWO YEAR WARRANTY applies. Warranty is valid only for the original purchaser of the unit.
- C) This warranty does not apply to damage resulting from abuse, misuse, accidents, shipping, and repairs or modifications by anyone other than an authorized Lightronics service representative.
- D) This warranty is void if the serial number is removed, altered or defaced.
- E) This warranty does not cover loss or damage, direct or indirect arising from the use or inability to use this product.
- F) Lightronics reserves the right to make any changes, modifications, or updates as deemed appropriate by Lightronics to products returned for service. Such changes may be made without prior notification to the user and without incurring any responsibility or liability for modifications or changes to equipment previously supplied. Lightronics is not responsible for supplying new equipment in accordance with any earlier specifications.
- G) This warranty is the only warranty either expressed, implied, or statutory, upon which the equipment is purchased. No representatives, dealers or any of their agents are authorized to make any warranties, guarantees, or representations other than expressly stated herein.
- H) This warranty does not cover the cost of shipping products to or from Lightronics for service.
- I) Lightronics Inc. reserves the right to make changes as deemed necessary to this warranty without prior notification.

